

KAISAI

R32 UNITS SERVICE MANUAL

KAISAI ECO4 INVERTER SERIES



KEX-09KTBI	KEX-09KTBO
KEX-12KTCI	KEX-12 KTBO
KEX-18KTBI	KEX-18 KTBO
KEX-24KTBI	KEX-24 KTBO

IMPORTANT NOTE:

Read this manual carefully before installing or operating your new air conditioning unit. Make sure to save this manual for future reference.

Table of Contents

Page

1. Safety Precautions	1
1. Precautions	
2. Information servicing	
2. Specifications	7
1. Model Reference	
2. Electrical Wiring Diagrams	
3. Product Features	13
1. Operation Modes and Functions	
4. Maintenance and Disassembly	20
1. Maintenance	
2. Disassembly	
5. Troubleshooting.....	59
1. Safety Caution	
2. General Troubleshooting	
3. Error Diagnosis and Troubleshooting Without Error Code	
4. Quick Maintenance by Error Code	
5. Troubleshooting by Error Code	
Appendix	86
i) Temperature Sensor Resistance Value Table for T1,T2,T3 and T4 (°C – K)	
ii) Temperature Sensor Resistance Value Table for TP (°C – K)	
iii) Pressure On Service Port	



Caution: Risk of fire/flammable material

Safety Precautions

Contents

1.	Precautions.....	2
2.	Information servicing.....	3

1. Precautions

To prevent personal injury, or property or unit damage, adhere to all precautionary measures and instructions outlined in this manual. Before servicing a unit, refer to this service manual and its relevant sections.

Failure to adhere to all precautionary measures listed in this section may result in personal injury, damage to the unit or to property, or in extreme cases, death.



WARNING indicates a potentially hazardous situation which if not avoided could result in serious personal injury, or death.



CAUTION indicates a potentially hazardous situation which if not avoided could result in minor or moderate personal injury, or unit damage.

1.1 In case of Accidents or Emergency



WARNING

- If a gas leak is suspected, immediately turn off the gas and ventilate the area if a gas leak is suspected before turning the unit on.
- If strange sounds or smoke is detected from the unit, turn the breaker off and disconnect the power supply cable.
- If the unit comes into contact with liquid, contact an authorized service center.
- If liquid from the batteries makes contact with skin or clothing, immediately rinse or wash the area well with clean water.
- Do not insert hands or other objects into the air inlet or outlet while the unit is plugged in.
- Do not operate the unit with wet hands.
- Do not use a remote controller that has previously been exposed to battery damage or battery leakage.



CAUTION

- Clean and ventilate the unit at regular intervals when operating it near a stove or near similar devices.
- Do not use the unit during severe weather conditions. If possible, remove the product from the window before such occurrences.

1.2 Pre-Installation and Installation



WARNING

- Use this unit only on a dedicated circuit.
- Damage to the installation area could cause the unit to fall, potentially resulting in personal injury, property damage, or product failure.
- Only qualified personnel should disassemble, install, remove, or repair the unit.
- Only a qualified electrician should perform electrical work. For more information, contact your dealer, seller, or an authorized KAISAI service center.



CAUTION

- While unpacking be careful of sharp edges around the unit as well as the edges of the fins on the condenser and evaporator.

1.3 Operation and Maintenance



WARNING

- Do not use defective or under-rated circuit breakers.
- Ensure the unit is properly grounded and that a dedicated circuit and breaker are installed.
- Do not modify or extend the power cable. Ensure the power cable is secure and not damaged during operation.
- Do not unplug the power supply plug during operation.
- Do not store or use flammable materials near the unit.
- Do not open the inlet grill of the unit during operation.
- Do not touch the electrostatic filter if the unit is equipped with one.
- Do not block the inlet or outlet of air flow to the unit.
- Do not use harsh detergents, solvents, or similar items to clean the unit. Use a soft cloth for cleaning.
- Do not touch the metal parts of the unit when removing the air filter as they are very sharp.
- Do not step on or place anything on the unit or outdoor units.
- Do not drink water drained from the unit
- Avoid direct skin contact with water drained from the unit.
- Use a firm stool or step ladder according to manufacturer procedures when cleaning or maintaining the unit.



CAUTION

- Do not install or operate the unit for an extended period of time in areas of high humidity or in an environment directly exposing it to sea wind or salt spray.
- Do not install the unit on a defective or damaged installation stand, or in an unsecure location.
- Ensure the unit is installed at a level position
- Do not install the unit where noise or air discharge created by the outdoor unit will negatively impact the environment or nearby residences.
- Do not expose skin directly to the air discharged by the unit for prolonged periods of time.
- Ensure the unit operates in areas water or other liquids.
- Ensure the drain hose is installed correctly to ensure proper water drainage.
- When lifting or transporting the unit, it is recommended that two or more people are used for this task.
- When the unit is not to be used for an extended time, disconnect the power supply or turn off the breaker.

2. Information servicing

2.1 Checks to the area

- Prior to beginning work on systems containing flammable refrigerants, safety checks are necessary to ensure that the risk of ignition is minimized.
- For repair to the refrigerating system, the following precautions shall be complied with prior to conducting work on the system.

2.2 Work procedure

- Work shall be undertaken under a controlled procedure so as to minimise the risk of a flammable gas or vapour being present while the work is being performed.

2.3 Work procedure

- All maintenance staff and others working in the local area shall be instructed on the nature of work being carried out.
- Work in confined spaces shall be avoided.
- The area around the work space shall be sectioned off. Ensure that the conditions within the area have been made safe by control of flammable material.

2.4 Checking for presence of refrigerant

- The area shall be checked with an appropriate refrigerant detector prior to and during work, to ensure the technician is aware of potentially flammable atmospheres.
- Ensure that the leak detection equipment being used is suitable for use with flammable refrigerants, i.e. no sparking, adequately sealed or intrinsically safe.

2.5 Presence of fire extinguisher

- If any hot work is to be conducted on the refrigeration equipment or any associated parts, appropriate fire extinguishing equipment shall be available to hand.
- Have a dry powder or CO₂ fire extinguisher adjacent to the charging area.

2.6 No ignition sources

- No person carrying out work in relation to a refrigeration system which involves exposing any pipe work that contains or has contained flammable refrigerant shall use any sources of ignition in such a manner that it may lead to the risk of fire or explosion.
- All possible ignition sources, including cigarette smoking, should be kept sufficiently far away from the site of installation, repairing, removing and disposal, during which flammable refrigerant can possibly be released to the surrounding space.
- Prior to work taking place, the area around the equipment is to be surveyed to make sure that there are no flammable

hazards or ignition risks.

- NO SMOKING signs shall be displayed.

2.7 Ventilated area

- Ensure that the area is in the open or that it is adequately ventilated before breaking into the
- system or conducting any hot work. A degree of ventilation shall continue during the period
- that the work is carried out. The ventilation should safely disperse any released refrigerant
- and preferably expel it externally into the atmosphere.

2.8 Checks to the refrigeration equipment

- Where electrical components are being changed, they shall be fit for the purpose and to the correct specification. At all times the manufacturer's maintenance and service guidelines shall be followed. If in doubt consult the manufacturer's technical department for assistance. The following checks shall be applied to installations using flammable refrigerants:
 - the charge size is in accordance with the room size within which the refrigerant containing parts are installed;
 - the ventilation machinery and outlets are operating adequately and are not obstructed;
 - if an indirect refrigerating circuit is being used, the secondary circuit shall be checked for the presence of refrigerant; marking to the equipment continues to be visible and legible.
 - markings and signs that are illegible shall be corrected;
 - refrigeration pipe or components are installed in a position where they are unlikely to be exposed to any substance which may corrode refrigerant containing components, unless the components are constructed of materials which are inherently resistant to being corroded or are suitably protected against being so corroded.

2.9 Checks to electrical devices

- Repair and maintenance to electrical components shall include initial safety checks and component inspection procedures. If a fault exists that could compromise safety, then no electrical supply shall be connected to the circuit until it is satisfactorily dealt with. If the fault cannot be corrected immediately but it is necessary to continue operation, an adequate temporary solution shall be used. This shall be reported to the owner of the equipment so all parties are advised. Initial safety checks shall include:

- that capacitors are discharged: this shall be done in a safe manner to avoid possibility of sparking;
- that there no live electrical components and wiring are exposed while charging, recovering or purging the system;
- that there is continuity of earth bonding.

2.10 Repairs to sealed components

- During repairs to sealed components, all electrical supplies shall be disconnected from the equipment being worked upon prior to any removal of sealed covers, etc. If it is absolutely necessary to have an electrical supply to equipment during servicing, then a permanently operating form of leak detection shall be located at the most critical point to warn of a potentially hazardous situation.
- Particular attention shall be paid to the following to ensure that by working on electrical components, the casing is not altered in such a way that the level of protection is affected. This shall include damage to cables, excessive number of connections, terminals not made to original specification, damage to seals, incorrect fitting of glands, etc.
 - Ensure that apparatus is mounted securely.
 - Ensure that seals or sealing materials have not degraded such that they no longer serve the purpose of preventing the ingress of flammable atmospheres. Replacement parts shall be in accordance with the manufacturer's specifications.

NOTE: The use of silicon sealant may inhibit the effectiveness of some types of leak detection equipment. Intrinsically safe components do not have to be isolated prior to working on them.

2.11 Repair to intrinsically safe components

- Do not apply any permanent inductive or capacitance loads to the circuit without ensuring that this will not exceed the permissible voltage and current permitted for the equipment in use. Intrinsically safe components are the only types that can be worked on while live in the presence of a flammable atmosphere. The test apparatus shall be at the correct rating.
- Replace components only with parts specified by the manufacturer. Other parts may result in the ignition of refrigerant in the atmosphere from a leak.

2.12 Cabling

- Check that cabling will not be subject to wear, corrosion, excessive pressure, vibration, sharp edges or any other adverse environmental effects. The check

shall also take into account the effects of aging or continual vibration from sources such as compressors or fans.

2.13 Detection of flammable refrigerants

- Under no circumstances shall potential sources of ignition be used in the searching for or detection of refrigerant leaks. A halide torch (or any other detector using a naked flame) shall not be used.

2.14 Leak detection methods

- The following leak detection methods are deemed acceptable for systems containing flammable refrigerants. Electronic leak detectors shall be used to detect flammable refrigerants, but the sensitivity may not be adequate, or may need re-calibration. (Detection equipment shall be calibrated in a refrigerant-free area.) Ensure that the detector is not a potential source of ignition and is suitable for the refrigerant used. Leak detection equipment shall be set at a percentage of the LFL of the refrigerant and shall be calibrated to the refrigerant employed and the appropriate percentage of gas (25 % maximum) is confirmed. Leak detection fluids are suitable for use with most refrigerants but the use of detergents containing chlorine shall be avoided as the chlorine may react with the refrigerant and corrode the copper pipe-work.
 - If a leak is suspected, all naked flames shall be removed or extinguished.
 - If a leakage of refrigerant is found which requires brazing, all of the refrigerant shall be recovered from the system, or isolated (by means of shut off valves) in a part of the system remote from the leak. Oxygen free nitrogen (OFN) shall then be purged through the system both before and during the brazing process.

2.15 Removal and evacuation

- When breaking into the refrigerant circuit to make repairs or for any other purpose, conventional procedures shall be used. However, it is important that best practice is followed since flammability is a consideration.
- The following procedure shall be adhered to:
 - remove refrigerant;
 - purge the circuit with inert gas;
 - evacuate;
 - purge again with inert gas;
 - open the circuit by cutting or brazing.

- The refrigerant charge shall be recovered into the correct recovery cylinders. The system shall be flushed with OFN to render the unit safe. This process may need to be repeated several times. Compressed air or oxygen shall not be used for this task. Flushing shall be achieved by breaking the vacuum in the system with OFN and continuing to fill until the working pressure is achieved, then venting to atmosphere, and finally pulling down to a vacuum. This process shall be repeated until no refrigerant is within the system. When the final OFN charge is used, the system shall be vented down to atmospheric pressure to enable work to take place. This operation is absolutely vital if brazing operations on the pipe-work are to take place.
- Ensure that the outlet for the vacuum pump is not close to any ignition sources and there is ventilation available.

2.16 Charging procedures

- In addition to conventional charging procedures, the following requirements shall be followed:
 - Ensure that contamination of different refrigerants does not occur when using charging equipment. Hoses or lines shall be as short as possible to minimize the amount of refrigerant contained in them.
 - Cylinders shall be kept upright.
 - Ensure that the refrigeration system is earthed prior to charging the system with refrigerant.
 - Label the system when charging is complete (if not already).
 - Extreme care shall be taken not to overfill the refrigeration system.
 - Prior to recharging the system it shall be pressure tested with OFN. The system shall be leak tested on completion of charging but prior to commissioning. A follow up leak test shall be carried out prior to leaving the site.

2.17 Decommissioning

Before carrying out this procedure, it is essential that the technician is completely familiar with the equipment and all its detail. It is recommended good practice that all refrigerants are recovered safely. Prior to the task being carried out, an oil and refrigerant sample shall be taken.

In case analysis is required prior to re-use of reclaimed refrigerant. It is essential that electrical power is available before the task is commenced.

- Become familiar with the equipment and its operation.
- Isolate system electrically.

- Before attempting the procedure ensure that:
 - mechanical handling equipment is available, if required, for handling refrigerant cylinders;
 - all personal protective equipment is available and being used correctly;
 - the recovery process is supervised at all times by a competent person;
 - recovery equipment and cylinders conform to the appropriate standards.
- Pump down refrigerant system, if possible.
- If a vacuum is not possible, make a manifold so that refrigerant can be removed from various parts of the system.
- Make sure that cylinder is situated on the scales before recovery takes place.
- Start the recovery machine and operate in accordance with manufacturer's instructions.
- Do not overfill cylinders. (No more than 80 % volume liquid charge).
- Do not exceed the maximum working pressure of the cylinder, even temporarily.
- When the cylinders have been filled correctly and the process completed, make sure that the cylinders and the equipment are removed from site promptly and all isolation valves on the equipment are closed off.
- Recovered refrigerant shall not be charged into another refrigeration system unless it has been cleaned and checked.

2.18 Labelling

- Equipment shall be labelled stating that it has been de-commissioned and emptied of
- refrigerant. The label shall be dated and signed. Ensure that there are labels on the equipment stating the equipment contains flammable refrigerant.

2.19 Recovery

- When removing refrigerant from a system, either for servicing or decommissioning, it is recommended good practice that all refrigerants are removed safely.
- When transferring refrigerant into cylinders, ensure that only appropriate refrigerant recovery cylinders are employed. Ensure that the correct numbers of cylinders for holding the total system charge are available. All cylinders to be used are designated for the recovered refrigerant and labelled for that refrigerant (i.e. special cylinders for the recovery of refrigerant). Cylinders shall be complete with pressure relief valve and associated shut-off valves in good working order.

-
- Empty recovery cylinders are evacuated and, if possible, cooled before recovery occurs.
 - The recovery equipment shall be in good working order with a set of instructions concerning the equipment that is at hand and shall be suitable for the recovery of flammable refrigerants. In addition, a set of calibrated weighing scales shall be available and in good working order.
 - Hoses shall be complete with leak-free disconnect couplings and in good condition. Before using the recovery machine, check that it is in satisfactory working order, has been properly maintained and that any associated electrical components are sealed to prevent ignition in the event of a refrigerant release. Consult manufacturer if in doubt.
 - The recovered refrigerant shall be returned to the refrigerant supplier in the correct recovery cylinder, and the relevant Waste Transfer Note arranged. Do not mix refrigerants in recovery units and especially not in cylinders.
 - If compressors or compressor oils are to be removed, ensure that they have been evacuated to an acceptable level to make certain that flammable refrigerant does not remain within the lubricant. The evacuation process shall be carried out prior to returning the compressor to the suppliers. Only electric heating to the compressor body shall be employed to accelerate this process. When oil is drained from a system, it shall be carried out safely.

Specifications

Contents

1.	Model Reference	8
2.	Electrical Wiring Diagrams.....	9
2.1	Indoor Unit	9
2.2	Outdoor Unit	11

1. Model Reference

Refer to the following table to determine the specific indoor and outdoor unit model number of your purchased equipment.

Indoor Unit Model	Outdoor Unit Model	Capacity (Btu)	Power Supply
KEX-09KTBI	KEX-09KTBO	9k	220-240V~, 50Hz, 1Phase
KEX-12KTCI	KEX-12 KTCO	12k	
KEX-18KTBI	KEX-18 KTBO	18k	
KEX-24KTBI	KEX-24 KTBO	24k	

2. Electrical Wiring Diagrams

2.1 Indoor unit

Abbreviation	Paraphrase
Y/G	Yellow-Green Conductor
ION	Positive and Negative Ion Generator
CAP	Capacitor
PLASMA	Electronic Dust Collector
L	LIVE
N	NEUTRAL
Heater	The Electric Heating Belt of Indoor Unit
T1	Indoor Room Temperature
T2	Coil Temperature of Indoor Heat Exchanger Middle

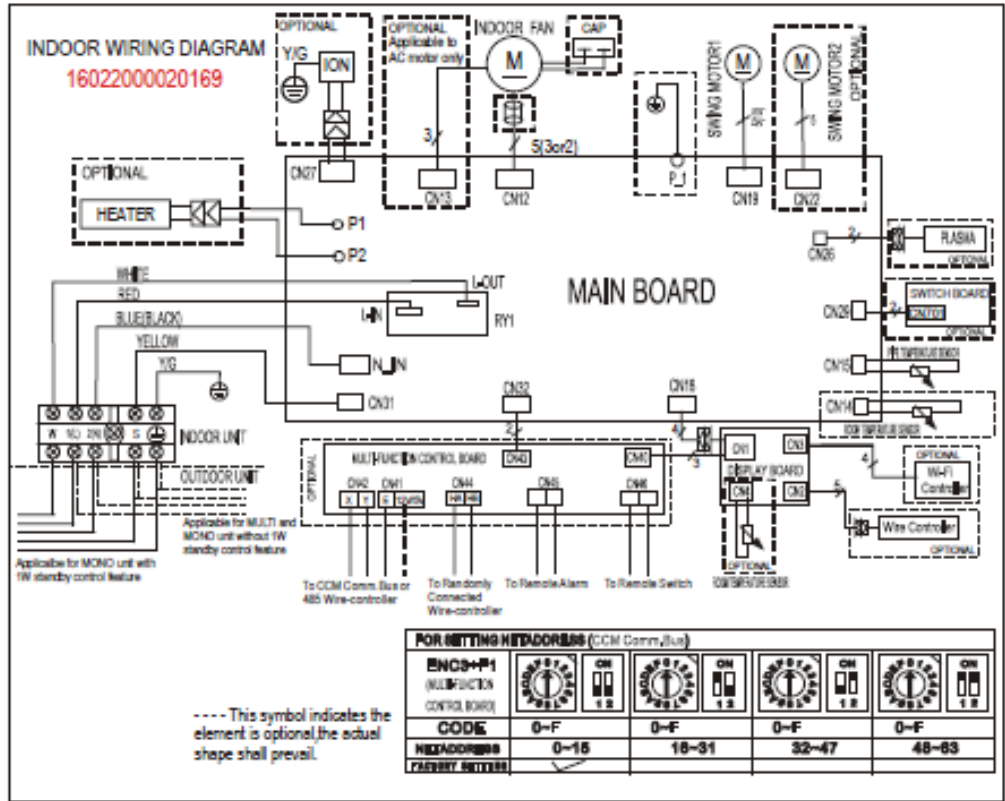

FOR SETTING NETADDRESS (CCM Comm. Bus)	
ENC3+F1 (MULTIFUNCTION CONTROL BOARD)	
FACTORY SETTING	

2.2 Outdoor Unit

Abbreviation	Paraphrase
4-WAY	Gas Valve Assembly/4-WAY VALVE
AC-FAN	Alternating Current FAN
DC-FAN	Direct Current FAN
CT1	AC Current Detector
COMP	Compressor
L-PRO	Low Pressure Switch
H-PRO	High Pressure Switch
EEV	Electronic Expansion Valve

KEX-09/12/18KTBO/KTCO

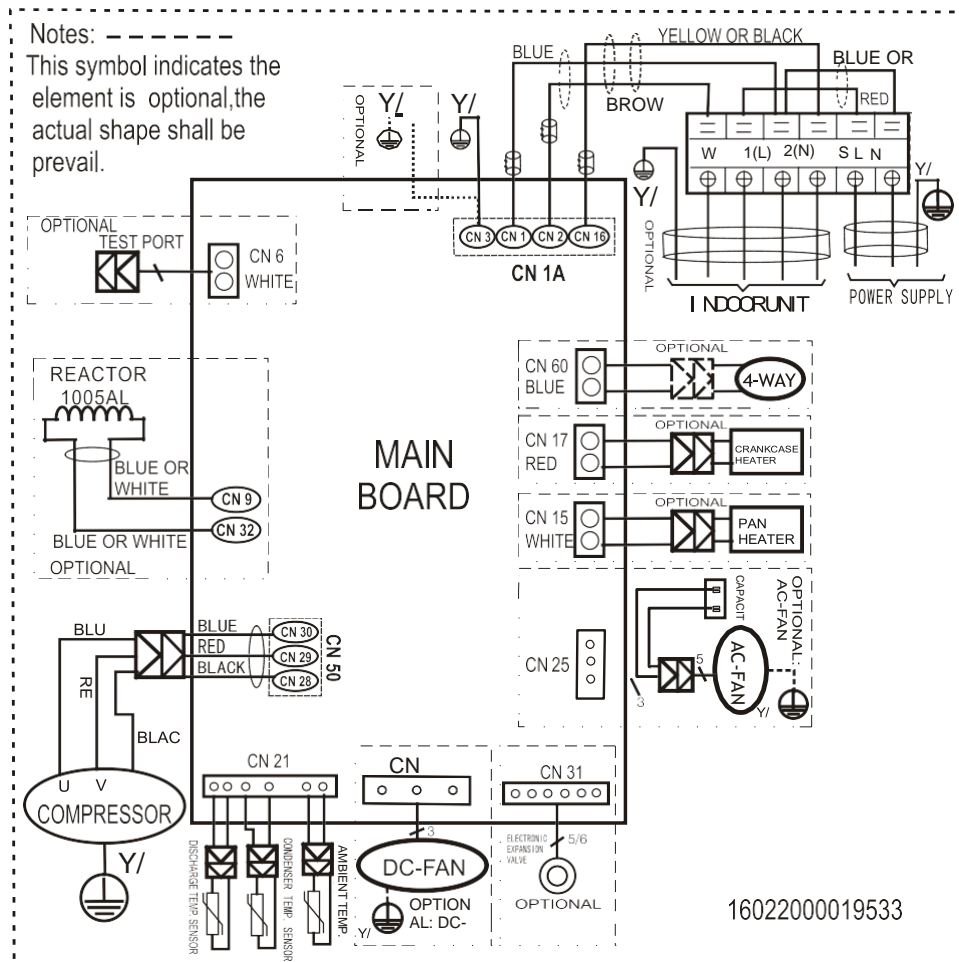

Product Features

Contents

1.	Operation Modes and Functions	14
1.1	Abbreviation	14
1.2	Safety Features	14
1.3	Display Function	14
1.4	Fan Mode.....	15
1.5	Cooling Mode.....	15
1.6	Heating Mode	15
1.7	Auto-mode	16
1.8	Drying Mode	16
1.9	Forced Operation Function	16
1.10	Sleep Function.....	16
1.11	Auto-Restart Function	16
1.12	Refrigerant Leakage Detection	17
1.13	8°C Heating(Optional).....	17
1.14	Self Clean(Optional).....	17
1.15	Follow Me(Optional).....	17
1.16	Silence (Optional).....	17
1.17	Information Inquiry	17

1. Operation Modes and Functions

1.1 Abbreviation

Unit element abbreviations

Abbreviation	Element
T1	Indoor room temperature
T2	Coil temperature of evaporator
T3	Coil temperature of condenser
T4	Outdoor ambient temperature
TS	Set temperature
TP	Compressor discharge temperature

1.2 Safety Features

Compressor three-minute delay at restart

Compressor functions are delayed for up to one minute upon the first startup of the unit, and are delayed for up to three minutes upon subsequent unit restarts.

Zero crossing detection error protection

If AC can not detect zero crossing signal for 4 minutes or the zero crossing signal time interval is not correct, the unit will stop and the LED will display the failure. The correct zero crossing signal time interval should be between 6-13ms.

Automatic shutoff based on discharge temperature

If the compressor discharge temperature exceeds 108°C for a period of time, the compressor ceases operation.

Automatic shutoff based on fan speed

If the indoor fan speed registers below 300RPM for an extended period of time, the unit ceases operation and the corresponding error code is displayed on the indoor unit.

Inverter module protection

The inverter module has an automatic shutoff mechanism based on the unit's current, voltage, and temperature. If automatic shutoff is initiated, the corresponding error code is displayed on the indoor unit and the unit ceases operation.

Indoor fan delayed operation

- When the unit starts, the louver is automatically activated and the indoor fan will operate after a period of 7 seconds.
- If the unit is in heating mode, the indoor fan is regulated by the anti-cold wind function.

Compressor preheating

Preheating is automatically activated when T4 sensor is lower than 3°C.

Sensor redundancy and automatic shutoff

- If one temperature sensor malfunctions, the air conditioner continues operation and displays the corresponding error code, allowing for emergency use.
- When more than one temperature sensor is malfunctioning, the air conditioner ceases operation.

Refrigerant leakage detection

This function is active only when cooling mode is selected. It will detect if the compressor is being damaged by refrigerant leakage or by compressor overload. This is measured using the coil temperature of evaporator T2 when the compressor is in operation.

1.3 Display Function

Unit display functions



Function	Display
Temperature	Set temperature value
Temperature (fan and Drying mode)	Room temperature
Activation of Timer ON, Fresh, Swing, Turbo, or Silent	ON (3s)
Cancellation of Timer OFF, Fresh, Swing, Turbo, or Silent	OF (3s)
Defrost	df
Warming in heating mode	cf
Self-clean (available on select units only)	sc
Heating in room temperature under 8°C	fp

1.4 Fan Mode

When fan mode is activated:

- The outdoor fan and compressor are stopped.
- Temperature control is disabled and no temperature setting is displayed.
- The indoor fan speed can be set to high, medium, low, or auto.
- The louver operations are identical to those in cooling mode.
- Auto fan: In fan-only mode, AC operates the same as auto fan in cooling mode with the temperature set at 24°C.

1.5 Cooling Mode

1.5.1 Compressor Control

ΔT means the temperature compensation.

- When $T1-Ts < \Delta T-2^{\circ}\text{C}$, the compressor ceases operation.
- When $T1-Ts > \Delta T+3^{\circ}\text{C}$, the compressor continues operation.
- When the AC is operating in mute mode, the compressor operates at a low frequency.
- When the current exceeds the preset value, the current protection function activates and the compressor ceases operation.

1.5.2 Indoor Fan Control

- In cooling mode, the indoor fan operates continuously. The fan speed can be set to high, medium, low, or auto.
- If the compressor ceases operations when the configured temperature is reached, the indoor fan motor operates at the minimum or configured speed.

1.5.3 Outdoor Fan Control

- The outdoor unit will be run at different fan speed according to T4 and compressor frequency.
- For different outdoor units, the fan speeds are different.

1.5.4 Condenser Temperature Protection

When condenser temperature is more than setting value, the compressor ceases operations..

1.5.5 Evaporator Temperature Protection

When evaporator temperature drops below a configured value, the compressor and outdoor fan cease operations.

1.6 Heating Mode

1.6.1 Compressor Control

ΔT means the temperature compensation.

- When $T1-Ts > -\Delta T$, the compressor ceases operation.
- When $T1-Ts < -\Delta T-1.5^{\circ}\text{C}$, the compressor continues operation.
- When the AC is operating in mute mode, the compressor operates at a low frequency.
- When the current exceeds the preset value, the current protection function activates and the compressor ceases operation.

1.6.2 Indoor Fan Control:

- When the compressor is on, the indoor fan can be set to high/medium/low/auto. And the anti-cold wind function has the priority.
- When indoor unit coil temp. is low, the anti-cold air function will start and indoor fan motor will run at low speed, the speed can't be changed, when the temp. is lower than setting value, the indoor fan motor will stop.
- When the indoor temp reaches the setting temp., the compressor will stop, the indoor fan motor will run at the minimum speed or setting speed. (The anti-cold air function is valid).

1.6.3 Outdoor Fan Control:

- The outdoor unit will be run at different fan speed according to T4 and compressor frequency.
- For different outdoor units, the fan speeds are different.

1.6.4 Defrosting mode

- The unit enters defrosting mode according to the temperature value of T3 and T4 as well as the compressor running time.
- In defrosting mode, the compressor continues to run, the indoor and outdoor motor will cease operation, the defrost light of the indoor unit will turn on, and the “” symbol is displayed.
- If any one of the following conditions is satisfied, defrosting ends and the machine switches to normal heating mode:
 - T3 rises above TCDE1°C.
 - T3 maintained above TCDE2°C for 80 seconds.
 - Unit runs for 15 minutes consecutively in defrosting mode.

1.6.5 Evaporator Temperature Protection

When the evaporator temperature exceeds a preset protection value, the compressor ceases operations.

1.7 Auto-mode

- This mode can be selected with the remote controller and the setting temperature can be changed between 17°C~30°C.
- In auto mode, the machine selects cooling, heating, or fan-only mode on the basis of ΔT ($\Delta T = T1 - Ts$).

ΔT	Running mode
$\Delta T > 2^\circ\text{C}$	Cooling
$-2^\circ\text{C} \leq \Delta T \leq 2^\circ\text{C}$	Fan-only
$\Delta T < -2^\circ\text{C}$	Heating*

Heating*: In auto mode, cooling only models run the fan

- The louver operates same as in relevant mode.
- If the machine switches mode between heating and cooling, the compressor will keep stopping for certain time and then choose mode according to $T1 - Ts$.
- If the setting temperature is modified, the machine will choose running function again.

1.8 Drying mode

- Indoor fan speed is fixed at breeze and can't be changed. The louver angle is the same as in cooling mode.
- All protections are active and the same as that in cooling mode.

1.9 Forced operation function

- Forced cooling mode:

The compressor and outdoor fan continue to run and the indoor fan runs at low speed. After running for 30 minutes, the AC will switch to auto mode with a preset temperature of 24°C.

- Forced auto mode:

Forced auto mode operates the same as normal auto mode with a preset temperature of 24°C.

- The unit exits forced operation when it receives the following signals:
 - Switch on
 - Switch off
 - Timer on
 - Timer off
 - Changes in:
 - mode
 - fan speed
 - sleeping mode

- Follow me

1.10 Sleep function

- The sleep function is available in cooling, heating, or auto mode.
- The operational process for sleep mode is as follows:
 - When cooling, the temperature rises 1°C (to not higher than 30°C) every hour. After 2 hours, the temperature stops rising and the indoor fan is fixed at low speed.
 - When heating, the temperature decreases 1°C (to not lower than 17°C) every hour. After 2 hours, the temperature stops decreasing and the indoor fan is fixed at low speed. Anti-cold wind function takes priority.
- The operating time for sleep mode is 7 hours, after which, the unit exits this mode and switches off.
- The timer setting is available in this mode.

1.11 Auto-Restart function

- The indoor unit has an auto-restart module that allows the unit to restart automatically. The module automatically stores the current settings (not including the swing setting) and, in the case of a sudden power failure, will restore those settings automatically within 3 minutes after power returns.
- If the unit was in forced cooling mode, it will run in this mode for 30 minutes and turn to auto mode with temperature set to 24°C.
- If there is a power failure while the unit is running, the compressor starts 3 minutes after the unit restarts. If the unit was already off before the power failure, the compressor starts 1 minute after the unit restarts.

1.12 Refrigerant Leakage Detection

With this new technology, the display area will show "EC" when the outdoor unit detects refrigerant leakage.

1.13 8°C Heating(Optional)

In heating mode, the temperature can be set to as low as 8°C, preventing the indoor area from freezing if unoccupied during severe cold weather.

1.14 Self clean(Optional)

- If you press "Self Clean" when the unit is in cooling or drying mode:
 - For cooling models, the indoor unit will run in low fan mode for a certain time, then ceases operation.

- For heat pump models, the indoor unit will run in fan-only mode, then low heat, and finally in fan-only mode.
- Self Clean keeps the indoor unit dry and prevents mold growth.

1.15 Follow me(Optional)

- If you press “Follow Me” on the remote, the indoor unit will beep. This indicates the follow me function is active.
- Once active, the remote control will send a signal every 3 minutes, with no beeps. The unit automatically sets the temperature according to the measurements from the remote control.
- The unit will only change modes if the information from the remote control makes it necessary, not from the unit’s temperature setting.
- If the unit does not receive a signal for 7 minutes or you press “Follow Me,” the function turns off. The unit regulates temperature based on its own sensor and settings.

1.16 Silence (Optional)

Press “Silence” on the remote control to enable the SILENCE function. While this function is active, the compressor frequency is maintained at a lower level than F2. The indoor unit will run at faint breeze, which reduces noise to the lowest possible level.

1.17 Information Inquiry

- To enter information inquiry status, complete the following procedure within ten seconds:
 - Press LED 3 times.
 - Press SWING 3 times.
- If you are successful, you will hear beeps for two seconds.
- Use the LED and SWING buttons to cycle through information displayed.
- Pressing LED will display the next code in the sequence. Pressing SWING will show the previous.
- The following table shows information codes. The screen will display this code for two seconds, then the information for 25 seconds.

Displayed code	Explanation	Displayed value	Meaning	Additional Notes
T1	Room temperature	-1F,-1E,-1d,-1c,-1b,-1A -19—99 A0,A1,...A9 b0,b1,...b9 c0,c1,...c9 d0,d1,...d9 E0,E1,...E9 F0,F1,...F9	-25,-24,-23,-22,-21,-20 -19—99 100,101,...109 110,111,...119 120,121,...129 130,131,...139 140,141,...149 150,151,...159	<ol style="list-style-type: none"> All displayed temperatures use actual values. All temperatures are displayed in °C regardless of remote used. T1, T2, T3, T4, and T2B display ranges from -25 to 70 °C. TP display ranges from -20 to 130 °C. The frequency display ranges from 0 to 159HZ. If the actual values exceed or fall short of the defined range, the values closest to the maximum and minimum values will be displayed.
T□	Indoor coil temperature			
T□	Outdoor coil temperature			
T4	Ambient temperature			
Tb	Outlet temperature of indoor coil			
TP	Discharge temperature			
TH	Suction temperature			
FT	Targeted frequency			
F□	Actual frequency			
IF	Indoor fan speed	0 1,2,3,4	OFF Low speed, Medium speed, High speed, Turbo.	N/A Used for some large capacity motors.
OF	Outdoor fan speed	14-FF	Actual fan speed is equal to the display value converted to decimal value and multiplied by 10. This is measured in RPM.	Used for some small capacity motors. The display value is 14-FF (hexadecimal). The corresponding fan speed ranges from 200 to 2550RPM.
L□	EXV opening angle	0-FF	Actual EXV opening value is equal to the display value converted to decimal value and then multiplied by 2.	-
CT	Compressor continuous running time	0-FF	0-255 minutes	If the actual value exceeds or falls short of the defined range, the value closest to the maximum and minimum will be displayed.
T	Causes of compressor stop	0-99	For a detailed explanation, contact technical support.	-

Displayed code	Explanation	Displayed value	Meaning	Additional Notes	
0	Reserved				
1					
0					
1					
b2					
b3					
4			0-FF		
b5			2-28	-	-
b6			5-20		
L			5-25		
Rc					
Uo					
T					
dR					
dS					
T					

Maintenance and Disassembly

Contents

1.	Maintenance.....	21
1.1	First Time Installation Check.....	21
1.2	Refrigerant Recharge.....	23
1.3	Re-Installation.....	24
1.3.1	Indoor Unit.....	24
1.3.2	Outdoor Unit.....	26
2.	Disassembly.....	28
2.1	Indoor Unit	28
2.2	Outdoor Unit	40

1. Maintenance

1.1 First Time Installation Check

Air and moisture trapped in the refrigerant system affects the performance of the air conditioner by:

- Increasing pressure in the system.
- Increasing the operating current.
- Decreasing the cooling or heating efficiency.
- Congesting the capillary tubing due to ice build-up in the refrigerant circuit.
- Corroding the refrigerant system.

To prevent air and moisture from affecting the air conditioner's performance, the indoor unit, as well as the pipes between the indoor and outdoor unit, must be leak tested and evacuated.

Leak test (soap water method)

Use a soft brush to apply soapy water or a neutral liquid detergent onto the indoor unit connections and outdoor unit connections. If there is gas leakage, bubbles will form on the connection.

Air purging with vacuum pump

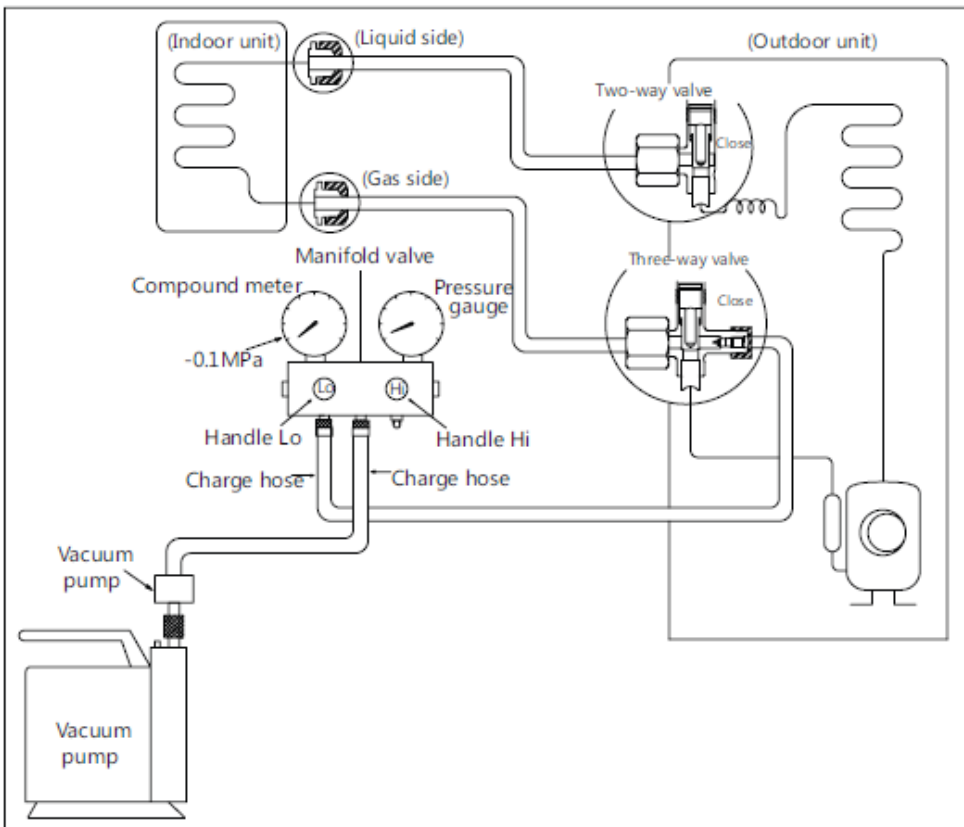

Procedure:

1. Tighten the flare nuts of the indoor and outdoor units, and confirm that both the 2- and 3-way valves are closed.
2. Connect the charge hose with the push pin of Handle Lo to the gas service port of the 3-way valve.
3. Connect another charge hose to the vacuum pump.
4. Fully open the Handle Lo manifold valve.
5. Using the vacuum pump, evacuate the system for 30 minutes.
 - a. Check whether the compound meter indicates -0.1 MPa (14.5 Psi).
 - If the meter does not indicate -0.1 MPa (14.5 Psi) after 30 minutes, continue evacuating for an additional 20 minutes.
 - If the pressure does not achieve -0.1 MPa (14.5 Psi) after 50 minutes, check for leakage.
 - b. If the pressure successfully reaches -0.1 MPa (14.5 Psi), fully close the Handle Lo valve, then cease vacuum pump operations.
 - b. Wait for 5 minutes then check whether the gauge needle moves after turning off the vacuum pump. If the gauge needle moves backward, check whether there is gas leakage.
6. Loosen the flare nut of the 3-way valve for 6 or 7 seconds and then tighten the flare nut again.
 - a. Confirm the pressure display in the pressure indicator is slightly higher than the atmospheric pressure.
 - b. Remove the charge hose from the 3-way valve.
7. Fully open the 2- and 3-way valves and tighten the cap of the 2- and 3-way valves.

1.2 Refrigerant Recharge

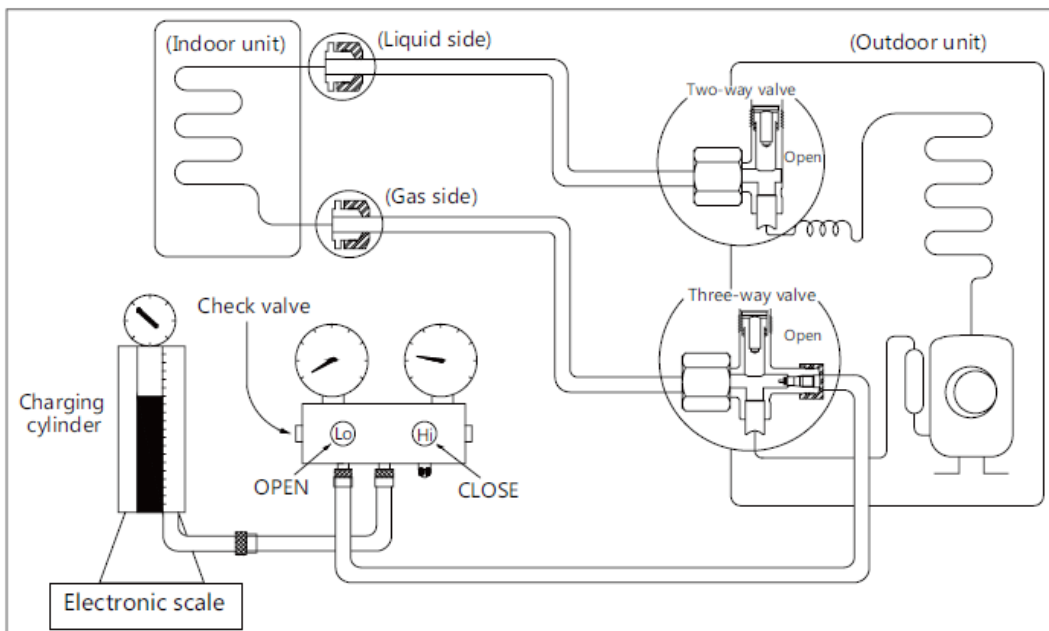

Prior to recharging the refrigerant, confirm the additional amount of refrigerant required using the following table:

Models	Standard length	Max. elevation	Max. length	Additional refrigerant
9k&12k	5m (16.4ft)	10m (32.8ft)	25m (82.0ft)	12g/m (0.13oz/ft)
18k	5m (16.4ft)	20m (65.6ft)	30m (98.4ft)	12g/m (0.13oz/ft)
24k	5m (16.4ft)	25m (82ft)	50m (164ft)	24g/m (0.26oz/ft)

Procedure:

1. Close both 2- and 3-way valves.
2. Slightly connect the Handle Lo charge hose to the 3-way service port.
3. Connect the charge hose to the valve at the bottom of the cylinder.
4. If the refrigerant is R410A, invert the cylinder to ensure a complete liquid charge.
5. Open the valve at the bottom of the cylinder for 5 seconds to purge the air in the charge hose, then fully tighten the charge hose with push pin Handle Lo to the service port of 3-way valve..
6. Place the charging cylinder onto an electronic scale and record the starting weight.
7. Fully open the Handle Lo manifold valve, 2- and 3-way valves.
8. Operate the air conditioner in cooling mode to charge the system with liquid refrigerant.
9. When the electronic scale displays the correct weight (refer to the gauge and the pressure of the low side to confirm), turn off the air conditioner, then disconnect the charge hose from the 3-way service port immediately..
10. Mount the caps of service port and 2- and 3-way valves.
11. Use a torque wrench to tighten the caps to a torque of 18 N.m.
12. Check for gas leakage.

1.3 Re-Installation

1.3.1 Indoor Unit

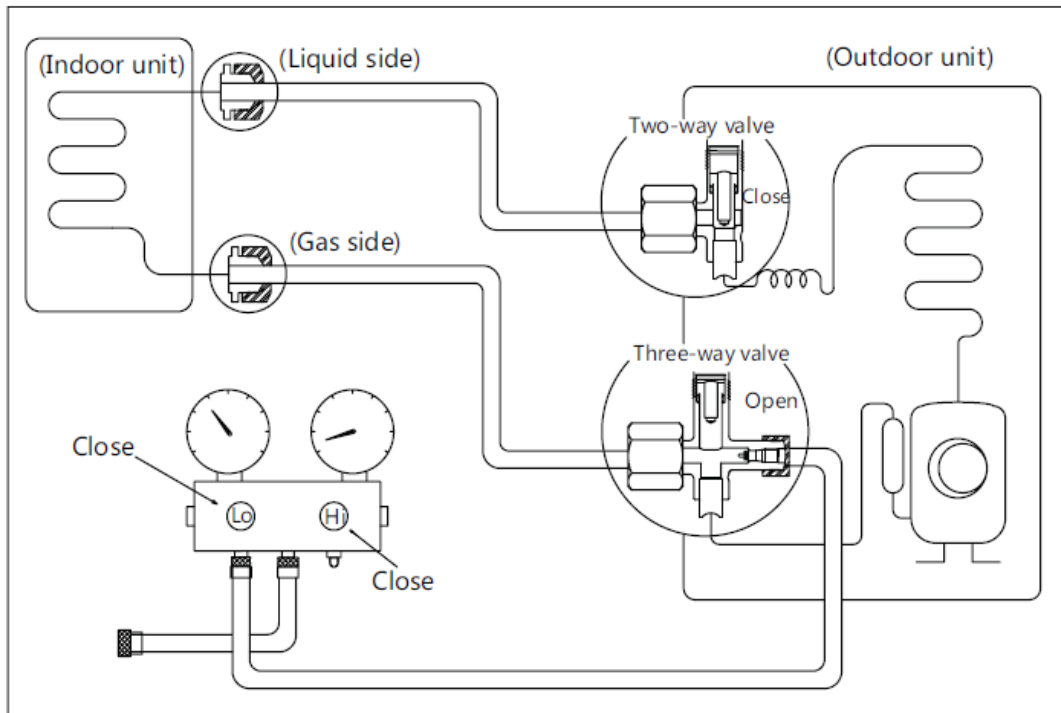

the outdoor unit

Collecting the refrigerant into

Procedure:

1. Confirm that the 2- and 3-way valves are opened.
2. Connect the charge hose with the push pin of Handle Lo to the 3-way valve's gas service port.
3. Open the Handle Lo manifold valve to purge air from the charge hose for 5 seconds and then close it quickly.
4. Close the 2-way valve.
5. Operate the air conditioner in cooling mode. Cease operations when the gauge reaches 0.1 MPa (14.5 Psi).
6. Close the 3-way valve so that the gauge rests between 0.3 MPa (43.5 Psi) and 0.5 MPa (72.5 Psi).
7. Disconnect the charge set and mount the caps of service port and 2- and 3-way valves.
8. Use a torque wrench to tighten the caps to a torque of 18 N.m.
9. Check for gas leakage.

Air purging with vacuum pump

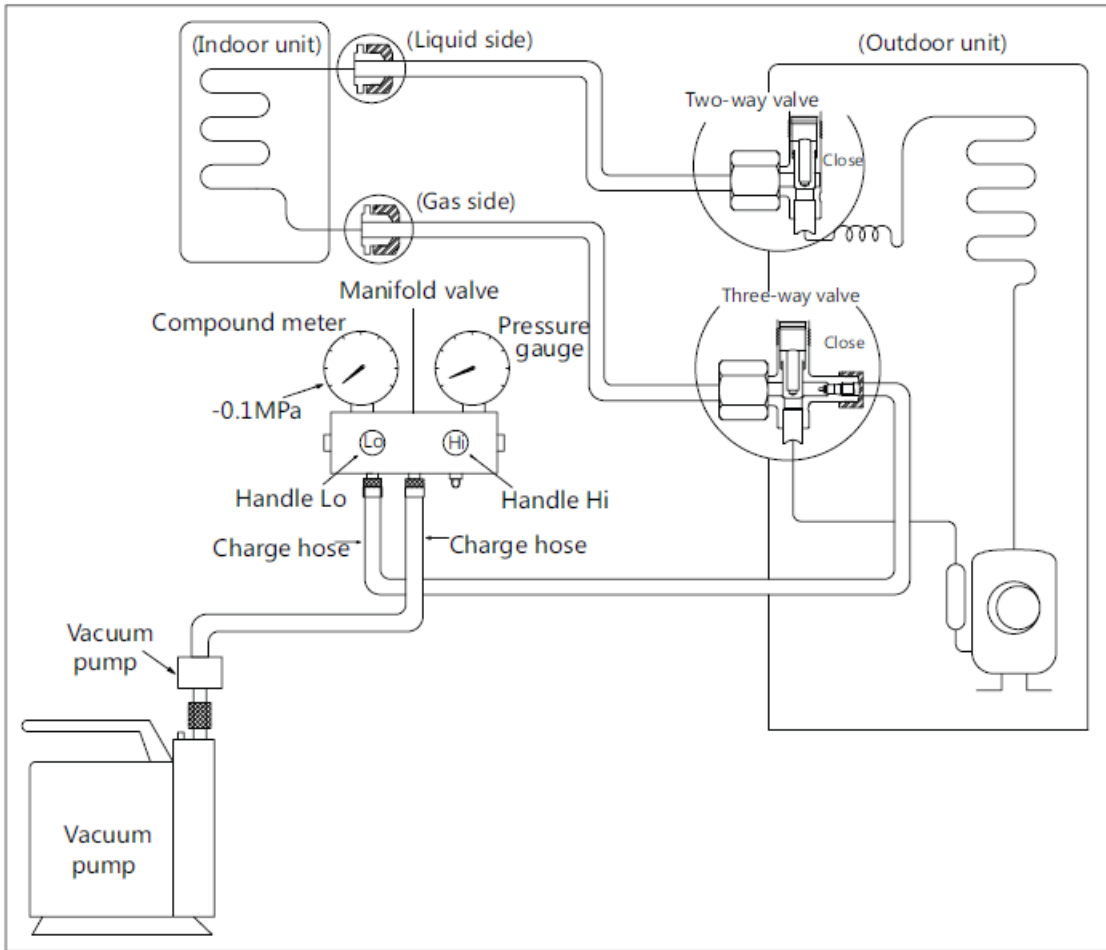

Procedure:

1. Tighten the flare nuts of the indoor and outdoor units, and confirm that both the 2- and 3-way valves are closed.
2. Connect the charge hose with the push pin of Handle Lo to the gas service port of the 3-way valve.
3. Connect another charge hose to the vacuum pump.
4. Fully open the Handle Lo manifold valve.
5. Using the vacuum pump, evacuate the system for 30 minutes.
 - a. Check whether the compound meter indicates -0.1 MPa (14.5 Psi).
 - If the meter does not indicate -0.1 MPa (14.5 Psi) after 30 minutes, continue evacuating for an additional 20 minutes.
 - If the pressure does not achieve -0.1 MPa (14.5 Psi) after 50 minutes, check for leakage.
 - If the pressure successfully reaches -0.1 MPa (14.5 Psi), fully close the Handle Lo valve, then cease vacuum pump operations.
 - b. Wait for 5 minutes then check whether the gauge needle moves after turning off the vacuum pump. If the gauge needle moves backward, check whether there is gas leakage.
6. Loosen the flare nut of the 3-way valve for 6 or 7 seconds and then tighten the flare nut again.
 - a. Confirm the pressure display in the pressure indicator is slightly higher than the atmospheric pressure.
 - b. Remove the charge hose from the 3-way valve.
7. Fully open the 2- and 3-way valves and tighten the cap of the 2- and 3-way valves.

1.3.2 Outdoor Unit

Evacuation for the whole system

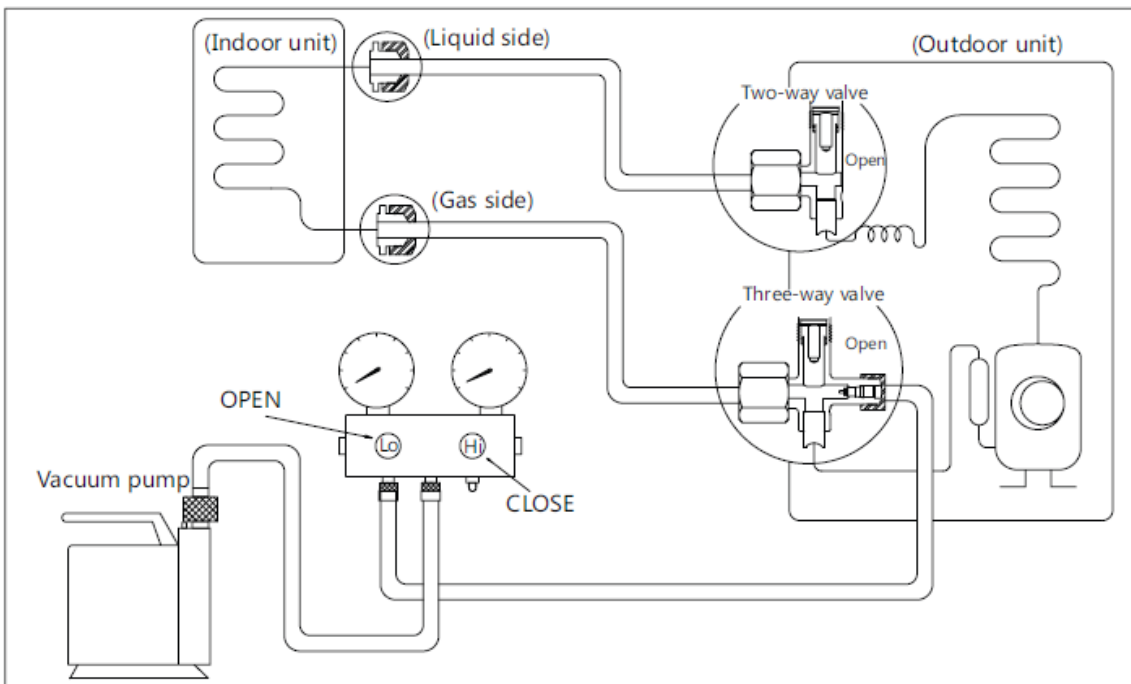

Procedure:

1. Confirm that the 2- and 3-way valves are opened.
2. Connect the vacuum pump to the 3-way valve's service port.
3. Evacuate the system for approximately one hour. Confirm that the compound meter indicates -0.1 MPa (14.5Psi).
4. Close the valve (Low side) on the charge set and turn off the vacuum pump.
5. Wait for 5 minutes then check whether the gauge needle moves after turning off the vacuum pump. If the gauge needle moves backward, check whether there is gas leakage.
6. Disconnect the charge hose from the vacuum pump.
7. Mount the caps of service port and 2- and 3-way valves.
8. Use a torque wrench to tighten the caps to a torque of 18 N.m.

Refrigerant charging

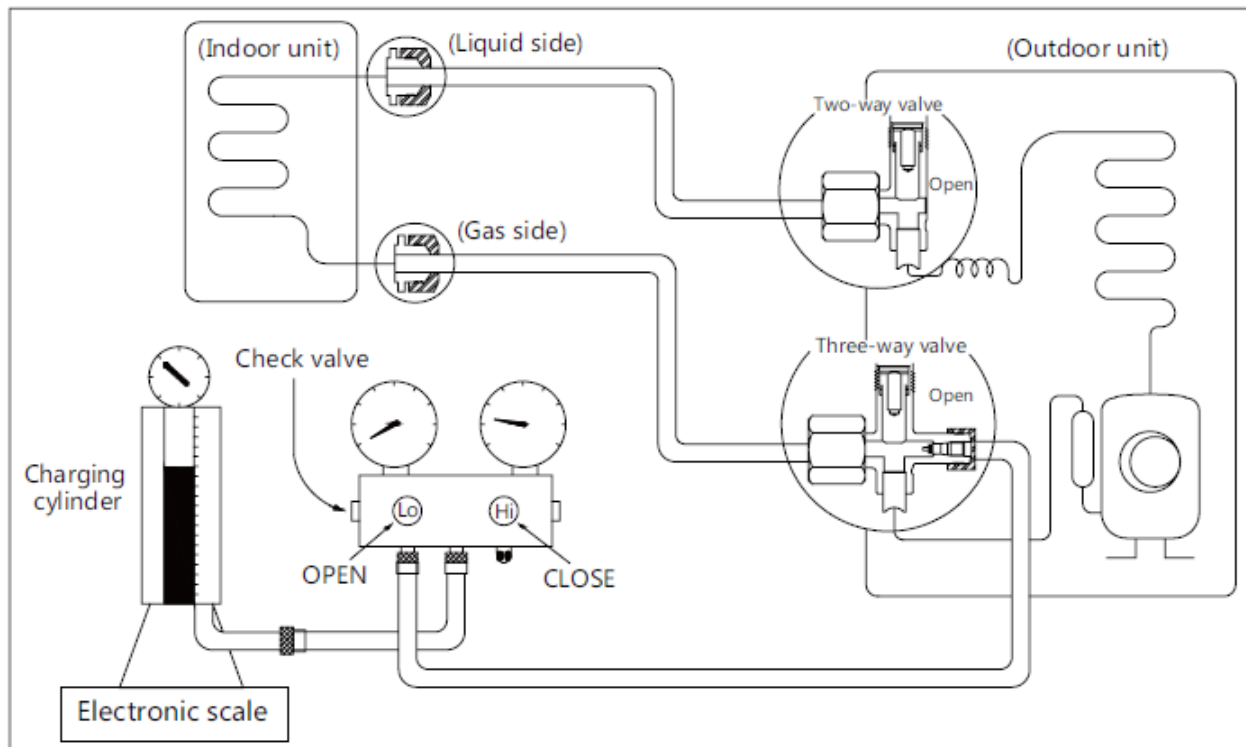

Procedure:

1. Close both 2- and 3-way valves.
2. Slightly connect the Handle Lo charge hose to the 3-way service port.
3. Connect the charge hose to the valve at the bottom of the cylinder.
4. If the refrigerant is R410A, invert the cylinder to ensure a complete liquid charge.
5. Open the valve at the bottom of the cylinder for 5 seconds to purge the air in the charge hose, then fully tighten the charge hose with push pin Handle Lo to the service port of 3-way valve..
6. Place the charging cylinder onto an electronic scale and record the starting weight.
7. Fully open the Handle Lo manifold valve, 2- and 3-way valves.
8. Operate the air conditioner in cooling mode to charge the system with liquid refrigerant.
9. When the electronic scale displays the correct weight (refer to the gauge and the pressure of the low side to confirm), turn off the air conditioner, then disconnect the charge hose from the 3-way service port immediately..
10. Mount the caps of service port and 2- and 3-way valves.
11. Use a torque wrench to tighten the caps to a torque of 18 N.m.
12. Check for gas leakage.

Note: 1. Mechanical connectors used indoors shall comply with local regulations.

2. When mechanical connectors are reused indoors, sealing parts shall be renewed. When flared joints are reused indoors, the flare part shall be re-fabricated.

2. Disassembly

2.1 Indoor unit

1. Front Panel

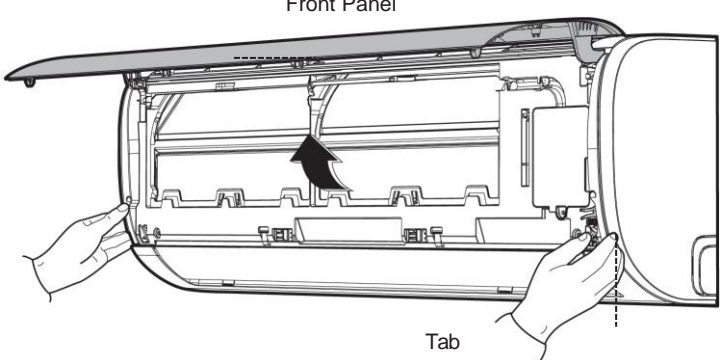
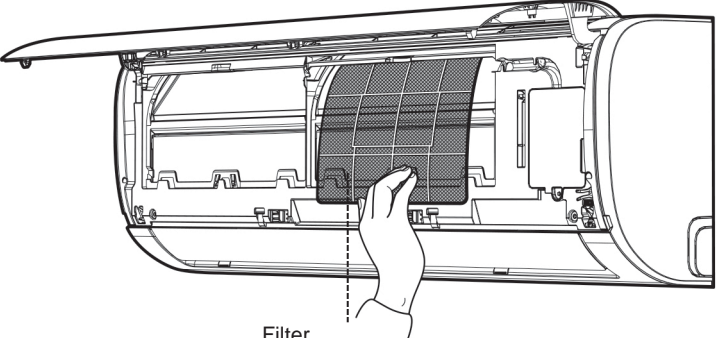
Procedure	Illustration
<p>1) Hold the front panel by the tabs on the both sides and lift it (see CJ_AF_INV_001).</p>	 <p>Front Panel</p> <p>Tab</p> <p>CJ_AF_INV_001</p>
<p>2) Push up the bottom of an air filter, and then pull it out downwards (see CJ_AF_INV_002).</p>	 <p>Filter</p> <p>CJ_AF_INV_002</p>

Note: This section is for reference only. Actual unit appearance may vary.

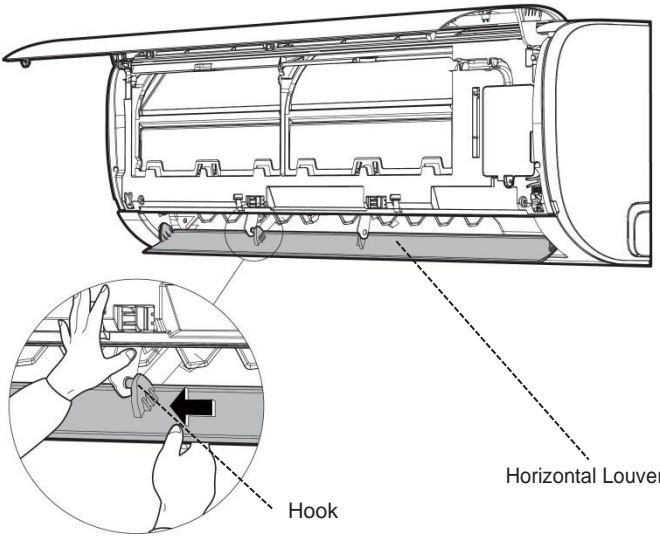
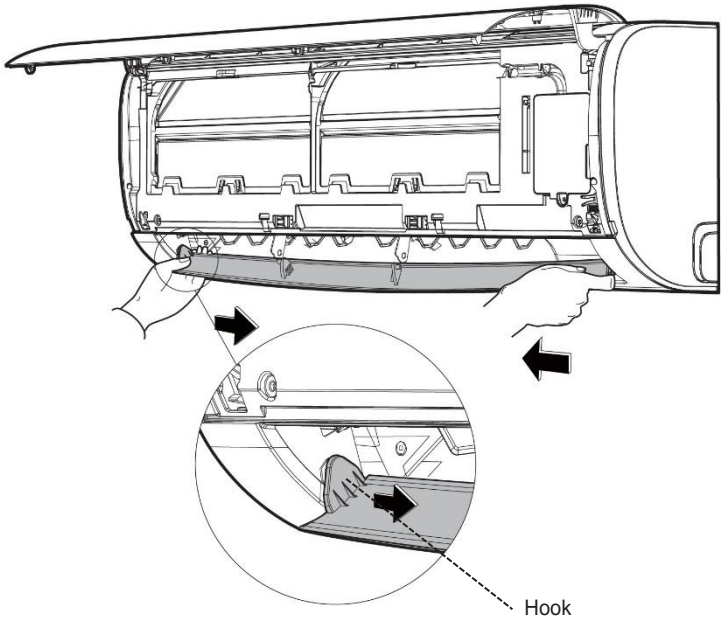
Procedure	Illustration
<p>3) Open the horizontal louver and push the hook towards left to open it (see CJ_AF_INV_003).</p>	 <p>The illustration shows a side view of the unit's interior with the horizontal louver partially open. A circular inset provides a close-up of a hand pushing a hook to the left. Labels include 'Hook' and 'Horizontal Louver'.</p> <p style="text-align: center;">CJ_AF_INV_003</p>
<p>4) Bend the horizontal louver lightly by both hands to loosen the hooks, then remove the horizontal louver (see CJ_AF_INV_004).</p>	 <p>The illustration shows the horizontal louver being bent downwards by two hands. A circular inset shows a close-up of the hook being disengaged from the louver. Labels include 'Hook'.</p> <p style="text-align: center;">CJ_AF_INV_004</p>

Note: This section is for reference only. Actual unit appearance may vary.

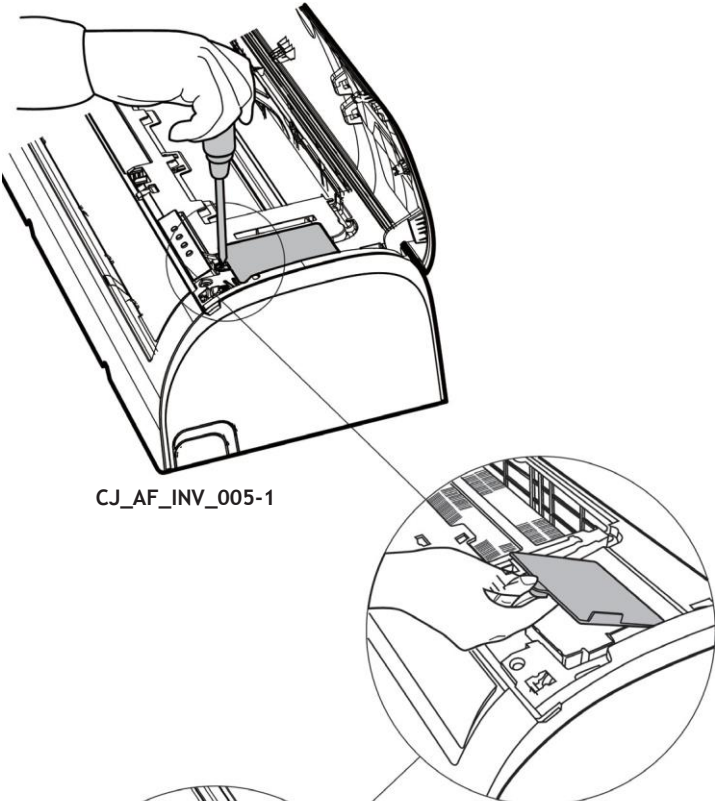
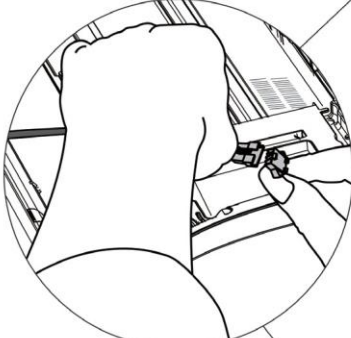
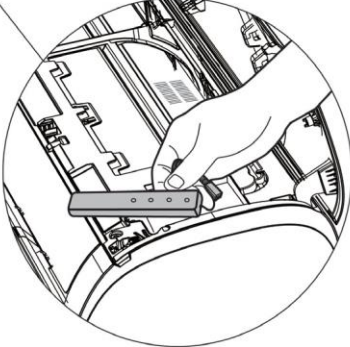
Procedure	Illustration
<p>5) Remove 1 screw and then remove the electrical cover(see CJ_AF_INV_005-1 and CJ_AF_INV_005-2).</p>	 <p>CJ_AF_INV_005-1</p> <p>CJ_AF_INV_005-2</p>
<p>6) Disconnect the connector for display board(see CJ_AF_INV_005-3).</p>	 <p>CJ_AF_INV_005-3</p>
<p>7) Remove the display board(see CJ_AF_INV_005-4).</p>	 <p>CJ_AF_INV_005-4</p> <p>CJ_AF_INV_005</p>

Note: This section is for reference only. Actual unit appearance may vary.

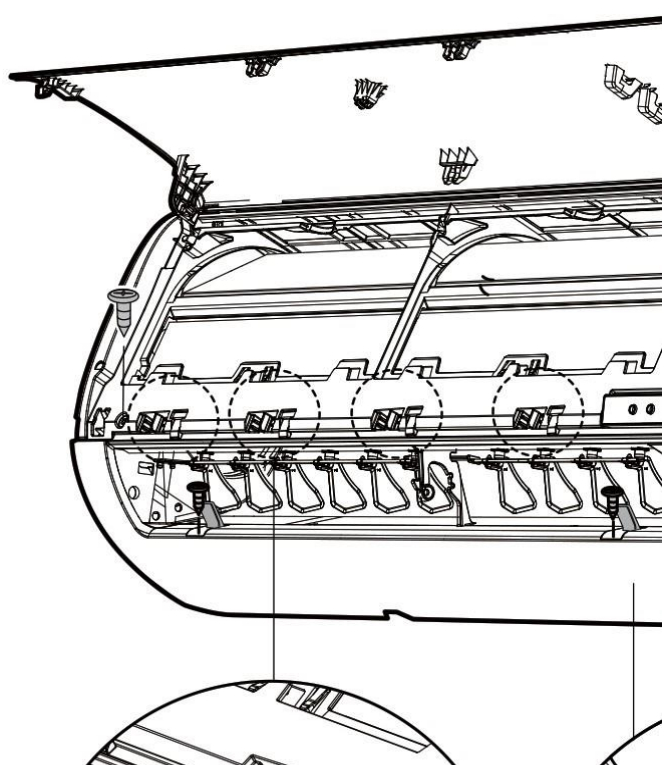
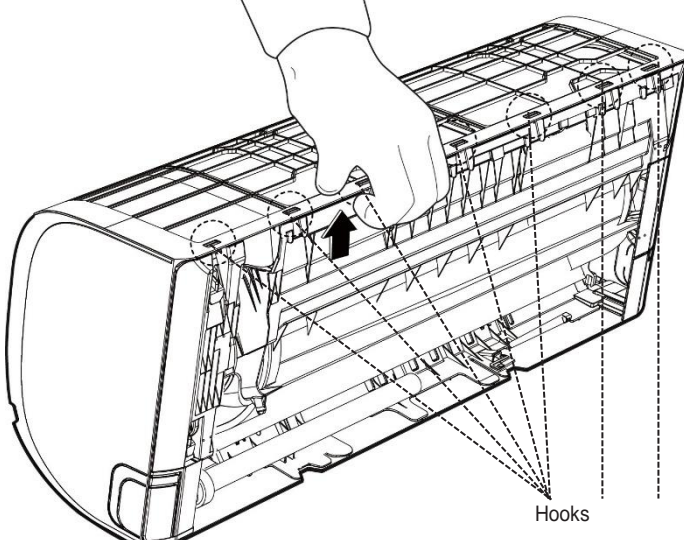
Procedure	Illustration
<p>8) Open the screw caps(2) and the remove the screws(see CJ_AF_INV_006).</p> <p>9) Release the 4 hooks.</p>	 <p style="text-align: center;">CJ_AF_INV_006</p>
<p>10) Release the seven hooks in the back (see CJ_AF_INV_007).</p>	 <p style="text-align: right;">Hooks</p> <p style="text-align: center;">CJ_AF_INV_007</p>

Note: This section is for reference only. Actual unit appearance may vary.

Procedure

11) Pull out the panel frame while pushing the hook through a clearance between the panel frame and the heat exchanger (see CJ_AF_INV_008).

Illustration

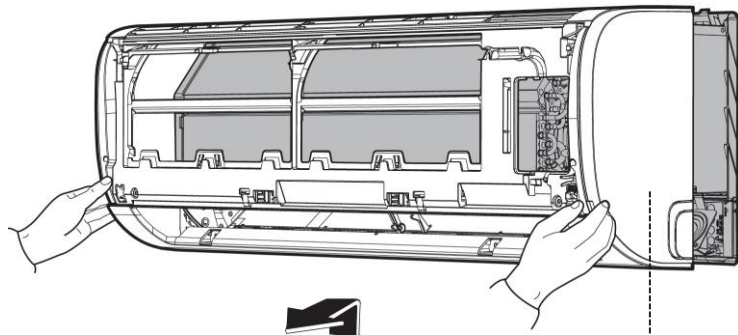

CJ_AF_INV_008

Panel Frame

Note: This section is for reference only. Actual unit appearance may vary.

2. Electrical parts

Note: Remove the front panel (refer to 1. Front panel) before disassembling electrical parts.

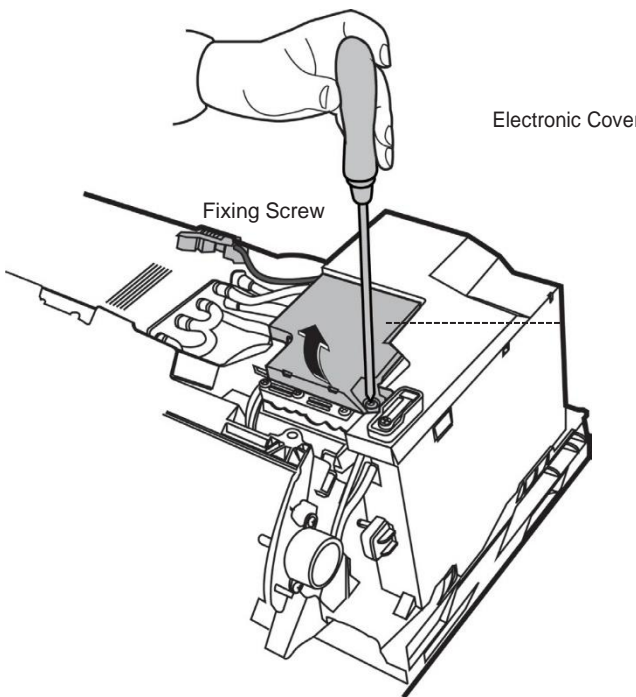
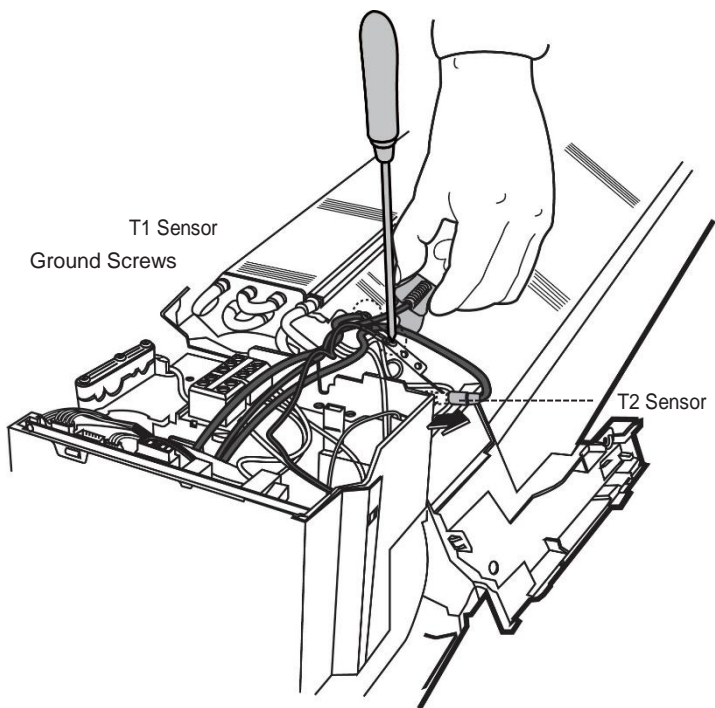
Procedure	Illustration
<p>1) Remove the fixing screw and then remove the cover of electronic box and the terminal cover (see CJ_AF_INV_009).</p>	 <p>CJ_AF_INV_009</p>
<p>2) Pull out the room temperature sensor (T1) and the coil temperature sensor (T2) (see CJ_AF_INV_010).</p> <p>3) Remove the two screws used for the ground connection (see CJ_AF_INV_010).</p>	 <p>CJ_AF_INV_010</p>

Note: This section is for reference only. Actual unit appearance may vary.

Procedure	Illustration
<p>4) Remove the fixing screw (see CJ_AF_INV_011-1).</p> <p>5) Pull out the Electrical control box along the direction indicated in right image. to remove it(CJ_AF_INV_011-2).</p>	<p>Fixing Screw</p> <p>CJ_AF_INV_011-1</p> <p>Electronic Box</p> <p>CJ_AF_INV_011-2</p> <p>Swing Motor ·····</p> <p>Applicable to AC Motor Only ·····</p> <p>Indoor Fan Motor ·····</p>
<p>6) Disconnect the wires. Then remove the electronic main board (CJ_AF_INV_012).</p>	<p>CJ_AF_INV_012</p> <p>Display Board ·····</p> <p>Pipe Temperature Sensor ·····</p> <p>Room Temperature Sensor ·····</p>

Note: This section is for reference only. Actual unit appearance may vary.

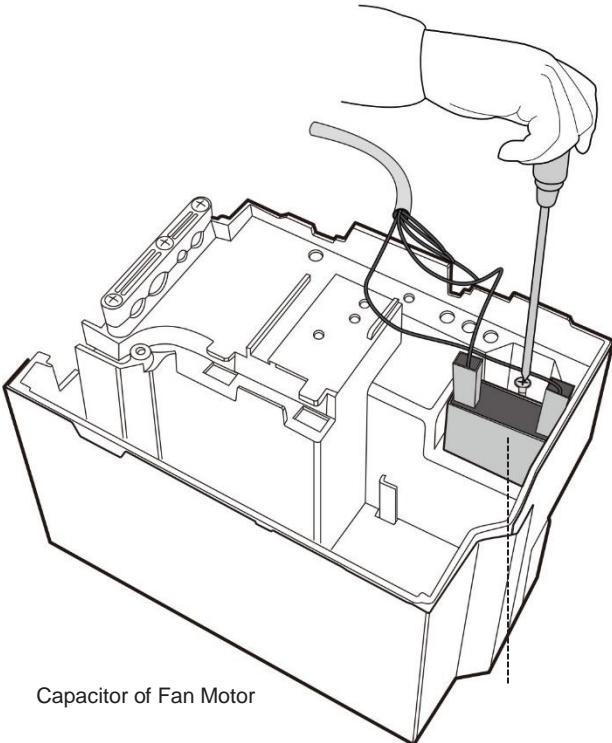
Procedure	Illustration
<p>7) Remove the fixing screw, then remove the capacitor of fan motor (see CJ_AF_INV_013).</p>	 <p>Capacitor of Fan Motor</p> <p>CJ_AF_INV_013</p>

Note: This section is for reference only. Actual unit appearance may vary.

3. Evaporator

Note: Remove the front panel and electrical parts (refer to 1. Front panel and 2. Electrical parts) before disassembling evaporator.

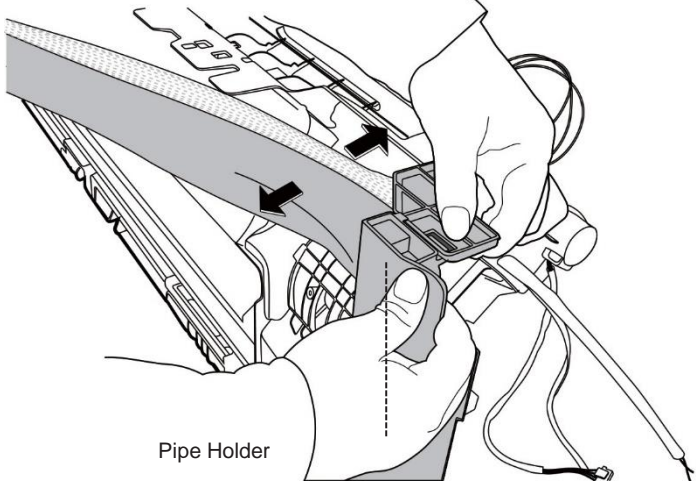
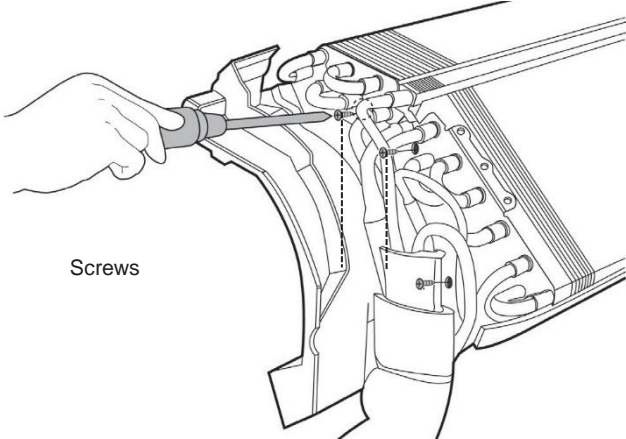
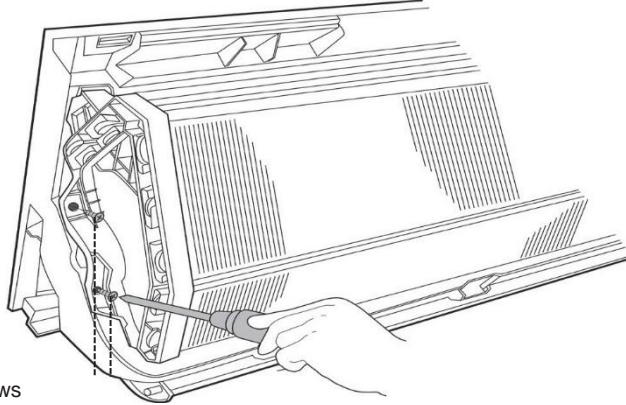
Procedure	Illustration
1) Disassemble the pipe holder located at the rear of the unit (see CJ_AF_INV_014).	 <p>Pipe Holder</p> <p>CJ_AF_INV_014</p>
2) Remove the screws on the evaporator located at the fixed plate (see CJ_AF_INV_015).	 <p>Screws</p> <p>CJ_AF_INV_015</p>
3) Remove the two screws on the evaporator located at the base of the bearing side (see CJ_AF_INV_016).	 <p>Screws</p> <p>CJ_AF_INV_016</p>

Note: This section is for reference only. Actual unit appearance may vary.

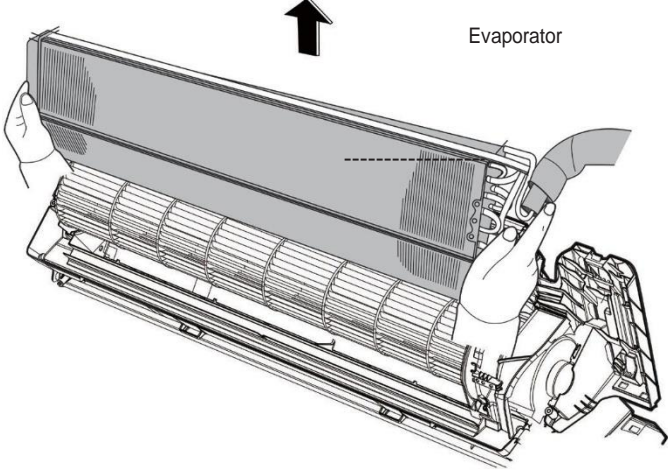
Procedure	Illustration
4) Pull out the evaporator (see CJ_AF_INV_017).	 <p data-bbox="938 860 1152 896">CJ_AF_INV_017</p>

Note: This section is for reference only. Actual unit appearance may vary.

4. Fan motor and fan

Note: Remove the front panel, electrical parts and evaporator (refer to 1. Front panel, 2. Electrical parts, and 3. Evaporator). before disassembling fan motor and fan.

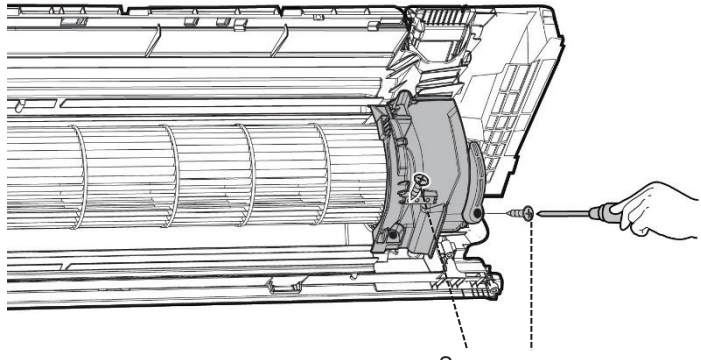
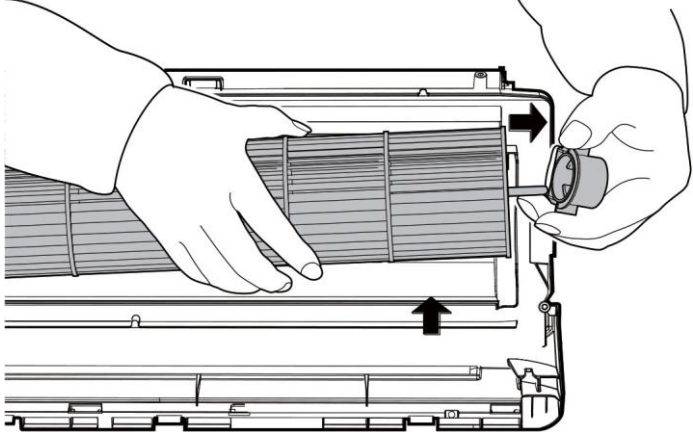
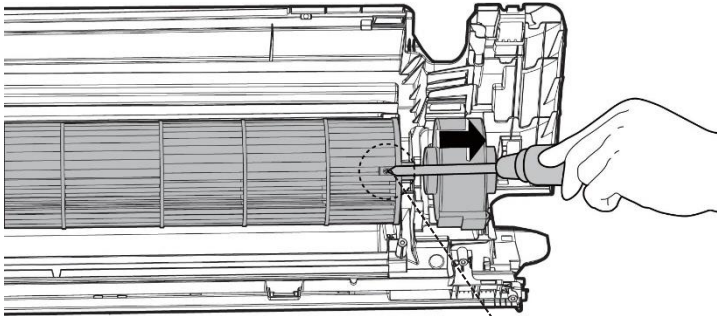
Procedure	Illustration
1) Remove the two screws and remove the fixing board of the fan motor (see CJ_AF_INV_018).	 <p data-bbox="938 869 1150 898">CJ_AF_INV_018</p>
2) Remove the Bearing sleeve(see CJ_AF_INV_019).	 <p data-bbox="938 1458 1150 1487">CJ_AF_INV_019</p>
3) Remove the fixing screw (see CJ_AF_INV_020). 4) Pull out the fan motor and fan assembly from the side.	 <p data-bbox="938 1917 1150 1946">CJ_AF_INV_020</p>

Note: This section is for reference only. Actual unit appearance may vary.

5. Step motor

Note: Remove the front panel and electrical parts (refer to 1. Front panel, 2. Electrical parts) before disassembling step motor.

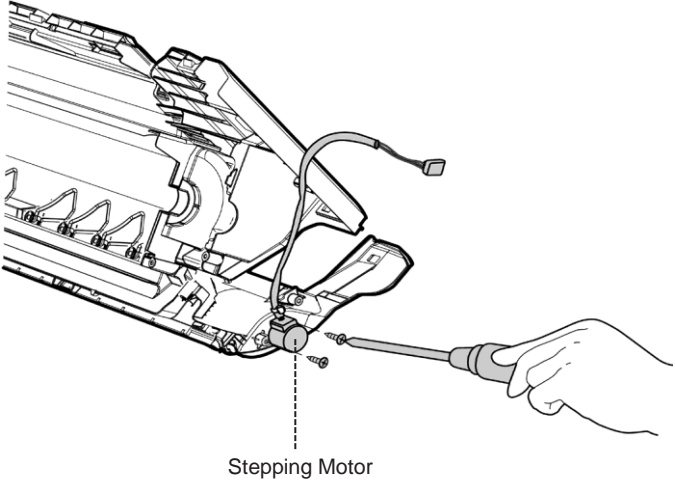
Procedure	Illustration
1) Remove the two screws, then remove the stepping motor (see CJ_AF_INV_021).	 <p data-bbox="935 902 1082 929">Stepping Motor</p> <p data-bbox="938 999 1145 1025">CJ_AF_INV_021</p>

Note: This section is for reference only. Actual unit appearance may vary.

2.2 Outdoor unit

1. Panel Plate

KEX-09/12KTBO,KTCO

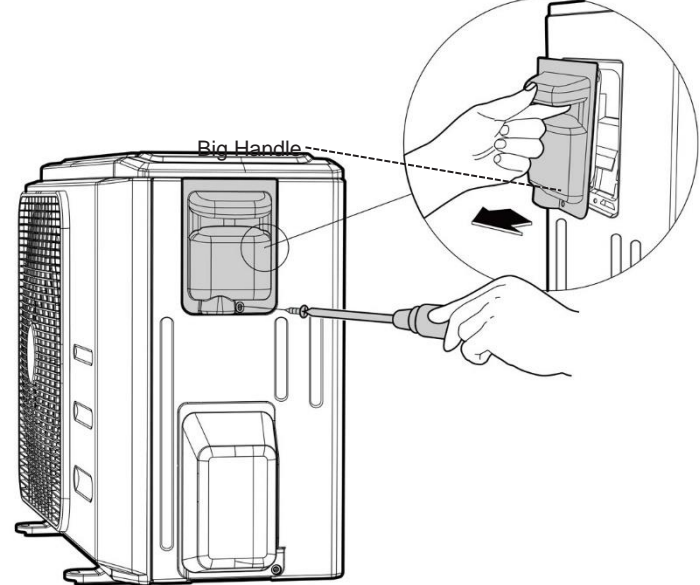
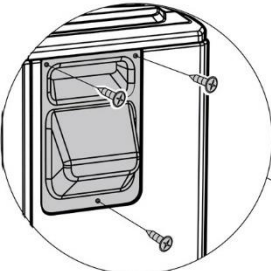
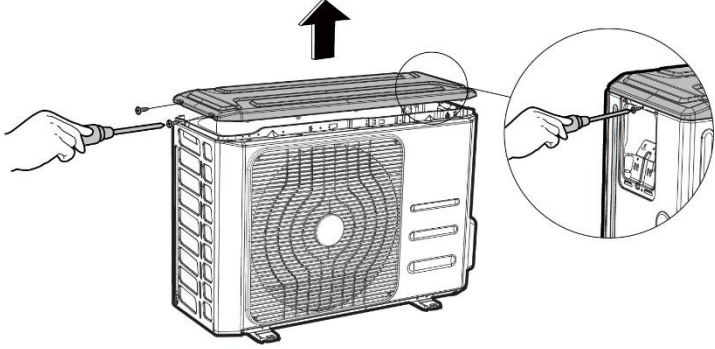
Procedure	Illustration
<p>1) Turn off the air conditioner and the power breaker.</p> <p>2) Remove the screws of the big handle and then remove the big handle (1 screws) (see CJ_AB30_INV_001).</p>	 <p>Big Handle</p>  <p>For US models (3 screws)</p> <p>CJ_AB30_INV_001</p>
<p>3) Remove the screws of the top cover and then remove the top cover (3 screws). One of the screws is located underneath the big handle (see CJ_AB30_INV_002).</p>	 <p>Top Cover</p> <p>CJ_AB30_INV_002</p>

Note: This section is for reference only. Actual unit appearance may vary.

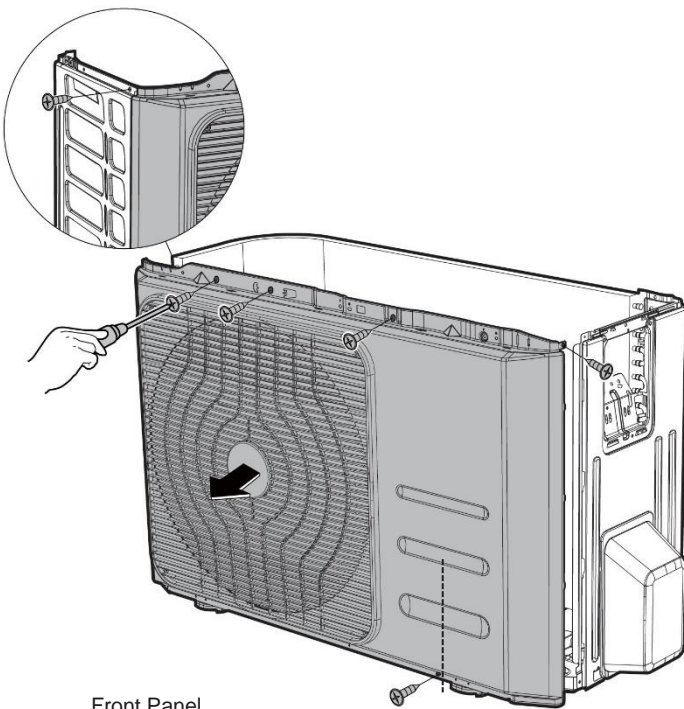
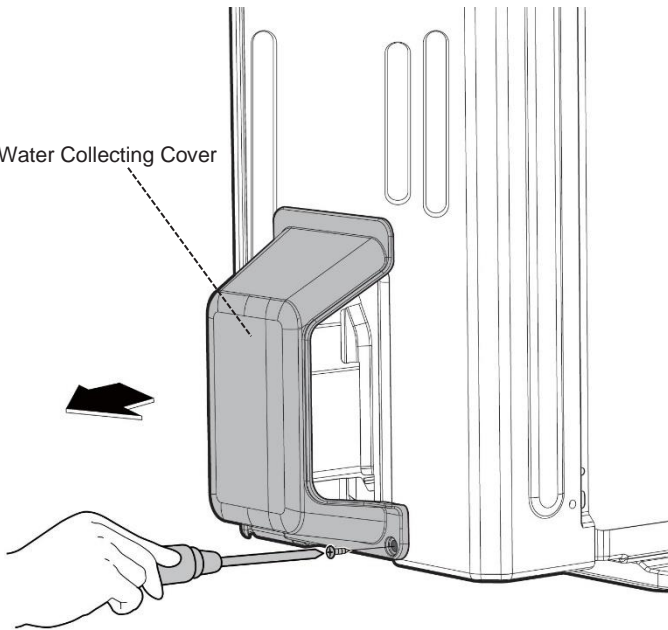
Procedure	Illustration
<p>4) Remove the screws of the front panel and then remove the front panel (6 screws) (see CJ_AB30_INV_003).</p>	 <p>Front Panel</p> <p>CJ_AB30_INV_003</p>
<p>5) Remove the screws of water collecting cover (1 screw) (see CJ_AB30_INV_004).</p>	 <p>Water Collecting Cover</p> <p>CJ_AB30_INV_004</p>

Note: This section is for reference only. Actual unit appearance may vary.

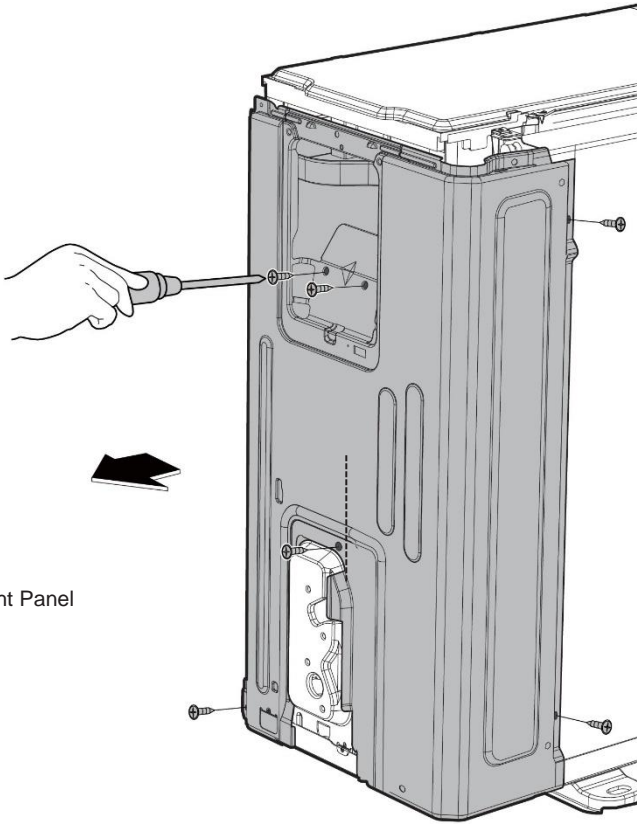
Procedure	Illustration
<p>1) Remove the screws of the right panel and then remove the right panel (5 screws) (see CJ_AB30_INV_005).</p>	 <p data-bbox="705 945 820 972">Right Panel</p> <p data-bbox="896 1240 1139 1267">CJ_AB30_INV_005</p>

Note: This section is for reference only. Actual unit appearance may vary.

KEX-18KTBO,

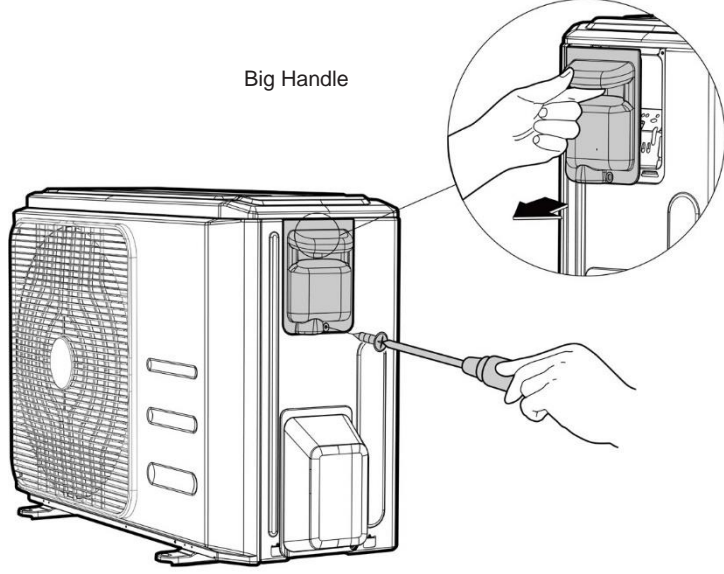
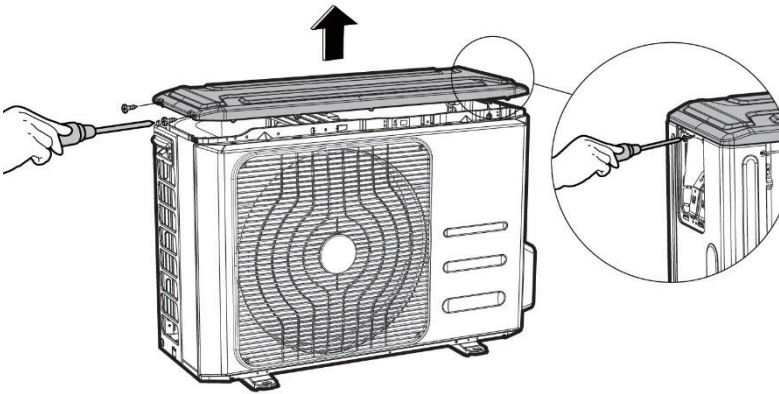
Procedure	Illustration
<p>1) Turn off the air conditioner and the power breaker.</p> <p>2) Remove the screws of the big handle and then remove the big handle (1 screws) (see CJ_B30_INV_001).</p>	 <p>Big Handle</p> <p>For US models (3 screws)</p>
<p>3) Remove the screws of the top cover and then remove the top cover (3 screws). One of the screws is located underneath the big handle (see CJ_B30_INV_002).</p>	 <p>Top Cover</p> <p>CJ_B30_INV_001</p> <p>CJ_B30_INV_002</p>

Note: This section is for reference only. Actual unit appearance may vary.

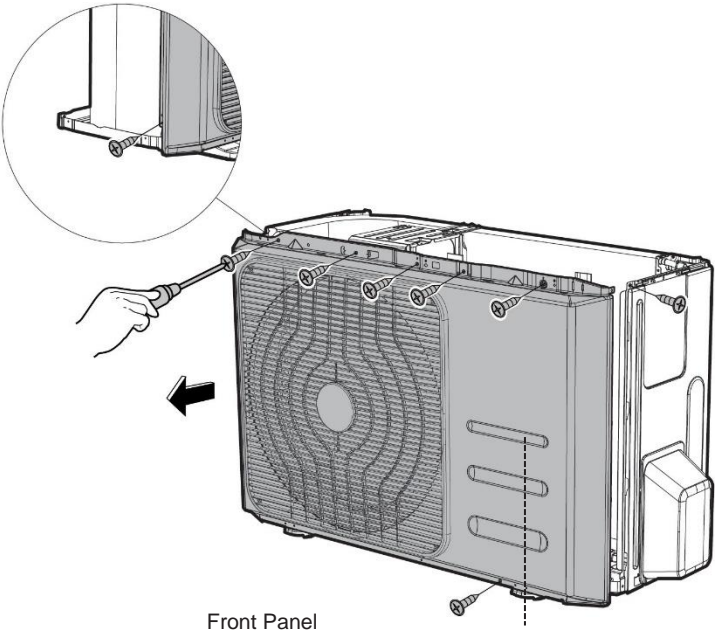
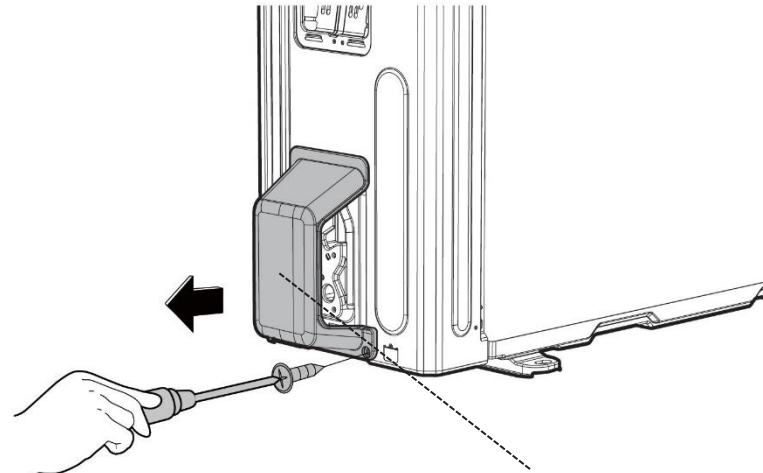
Procedure	Illustration
<p>1) Remove the screws of the front panel and then remove the front panel (8 screws) (see CJ_B30_INV_003).</p>	 <p>Front Panel</p> <p>CJ_B30_INV_003</p>
<p>2) Remove the screws of water collecting cover and then remove the water collecting cover (1 screw) (see CJ_B30_INV_004).</p>	 <p>Water Collecting Cover</p> <p>CJ_B30_INV_004</p>

Note: This section is for reference only. Actual unit appearance may vary.

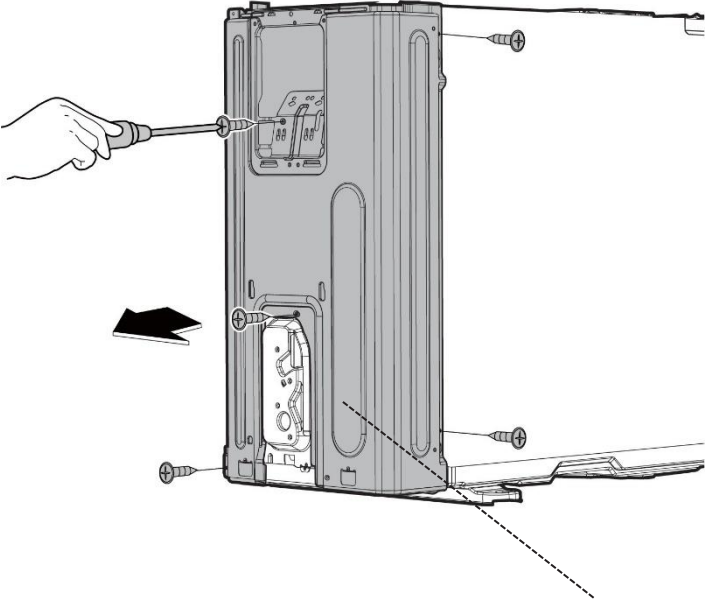
Procedure	Illustration
<p>3) Remove the screws of the right panel and then remove the right panel (5 screws) (see CJ_B30_INV_005).</p>	 <p>CJ_B30_INV_005</p> <p>Right Panel</p>

Note: This section is for reference only. Actual unit appearance may vary.

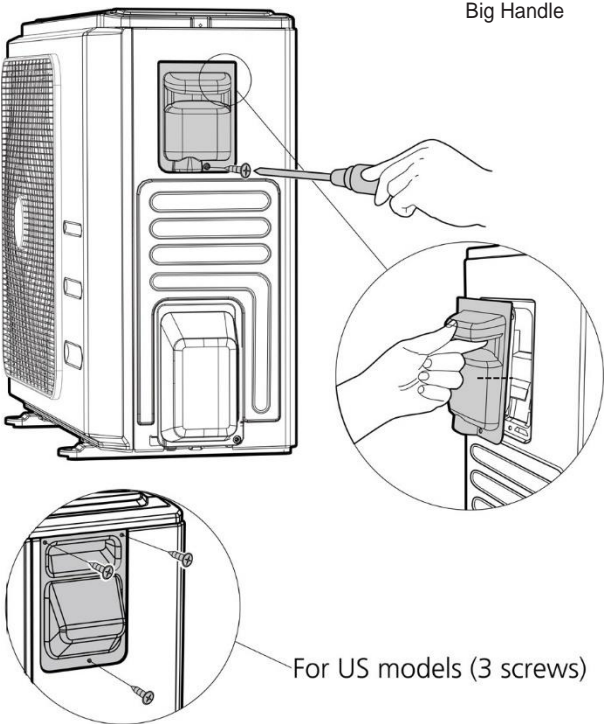
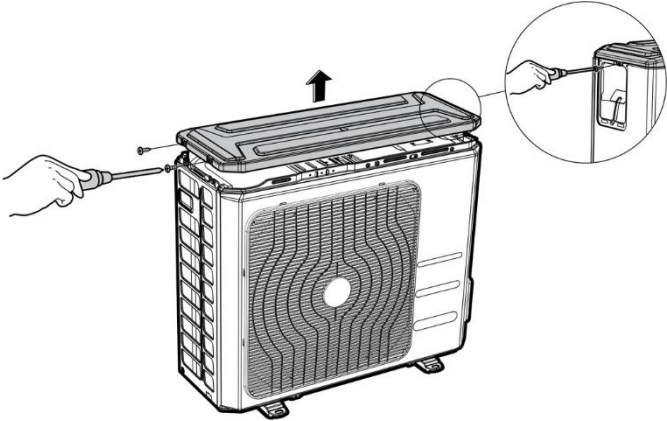
Procedure	Illustration
<p>1) Turn off the air conditioner and the power breaker.</p> <p>2) Remove the screws of the big handle and then remove the big handle (1 screws) (see CJ_CA30_INV_001).</p>	 <p>Big Handle</p> <p>For US models (3 screws)</p> <p>CJ_CA30_INV_001</p>
<p>3) Remove the screws of the top cover and then remove the top cover (3 screws). One of the screws is located underneath the big handle (see CJ_CA30_INV_002).</p>	 <p>Top Cover</p> <p>CJ_CA30_INV_002</p>

Note: This section is for reference only. Actual unit appearance may vary.

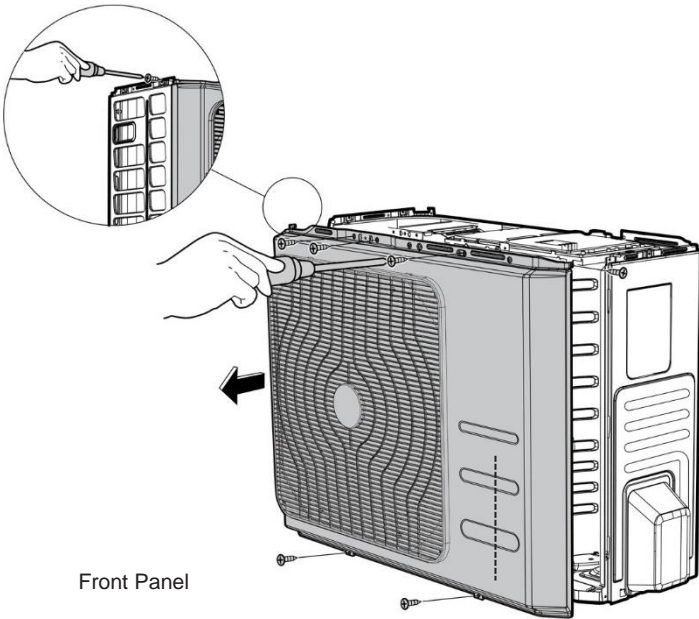
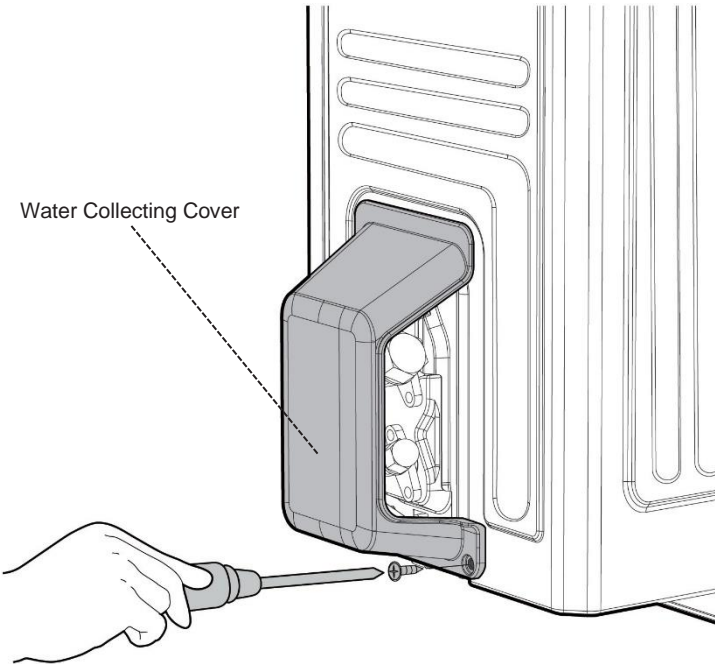
Procedure	Illustration
<p>4) Remove the screws of the front panel and then remove the front panel (7 screws) (see CJ_CA30_INV_003).</p>	 <p>Front Panel</p> <p>CJ_CA30_INV_003</p>
<p>5) Remove the screws of water collecting cover and then remove the water collecting cover (1 screw) (see CJ_CA30_INV_004).</p>	 <p>Water Collecting Cover</p> <p>CJ_CA30_INV_004</p>

Note: This section is for reference only. Actual unit appearance may vary.

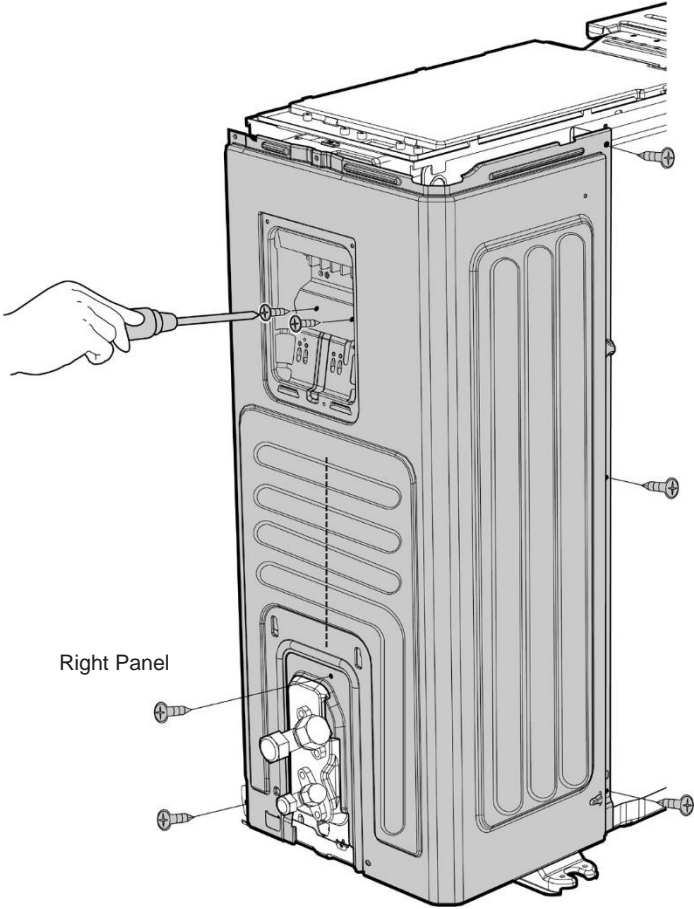
Procedure	Illustration
<p>1) Remove the screws of the right panel and then remove the right panel (6 screws) (see CJ_CA30_INV_005).</p>	 <p data-bbox="895 1373 1139 1406">CJ_CA30_INV_005</p>

Note: This section is for reference only. Actual unit appearance may vary.

2. Fan disassembly

Note: Remove the panel plate and (refer to 1. Panel plate) before disassembling fan.

KEX-18KTBO

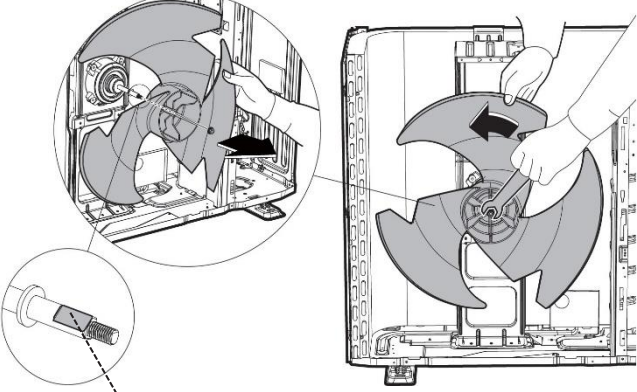
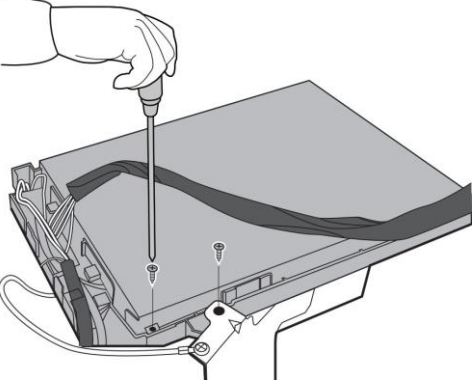
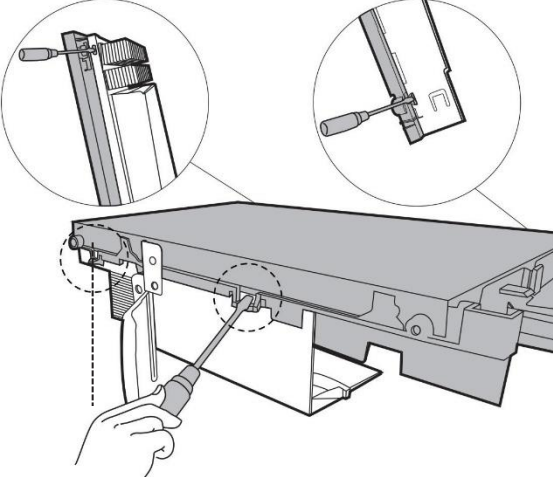
Procedure	Illustration
<p>1) Remove the nut securing the fan with a spanner (see CJ_ODU_INV_001).</p> <p>2) Remove the fan.</p>	 <p>D-cut CJ_ODU_INV_001</p>
<p>3) Remove the screws of the top cover. (2 screws) (see CJ_ODU_INV_002).</p>	 <p>CJ_ODU_INV_002</p>
<p>4) Unfix the hooks and then open the electronic control box cover (4 hooks) (see CJ_ODU_INV_003).</p>	 <p>Hook CJ_ODU_INV_003</p>

Note: This section is for reference only. Actual unit appearance may vary.

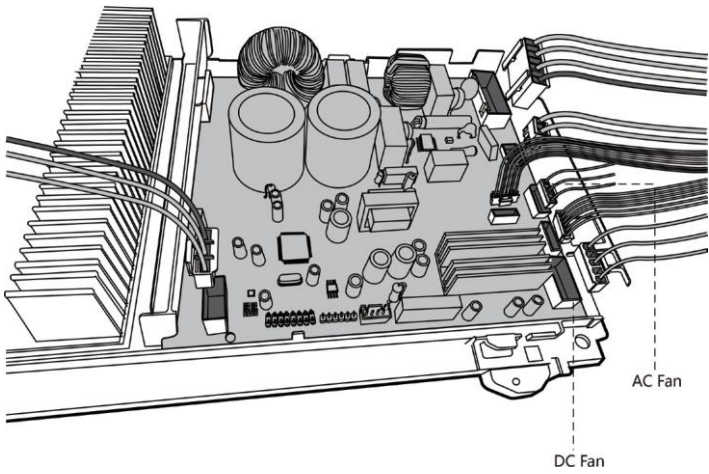
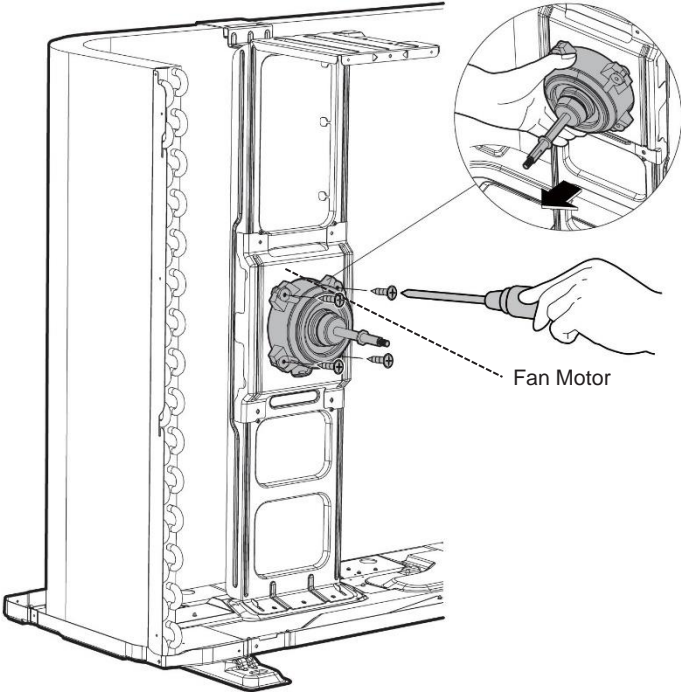
Procedure	Illustration
<p>5) Disconnect the connector for fan motor from the electronic control board (see CJ_ODU_INV_004).</p>	 <p>The diagram shows a top-down view of an electronic control board. On the left, there are several rows of connectors. In the center, there are two large cylindrical capacitors. On the right, there are two fans: one labeled 'AC Fan' and one labeled 'DC Fan'. Wires are connected to various components on the board.</p> <p>CJ_ODU_INV_004</p>
<p>6) Remove the fixing screws of the fan motor (4 screws) (see CJ_ODU_INV_005).</p> <p>7) Remove the fan motor.</p>	 <p>The diagram shows a vertical unit with its front panel removed. A hand is using a screwdriver to remove screws from a fan motor mounted on the side of the unit. An inset circular diagram shows a close-up of the fan motor being unscrewed. The label 'Fan Motor' points to the component.</p> <p>CJ_ODU_INV_005</p>

Note: This section is for reference only. Actual unit appearance may vary.

KEX-24KTBO

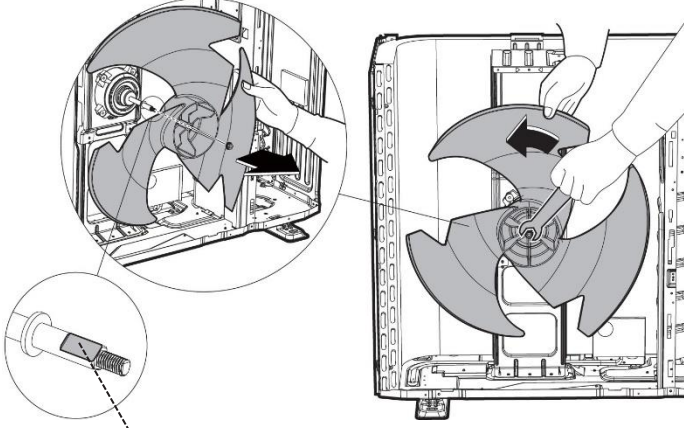
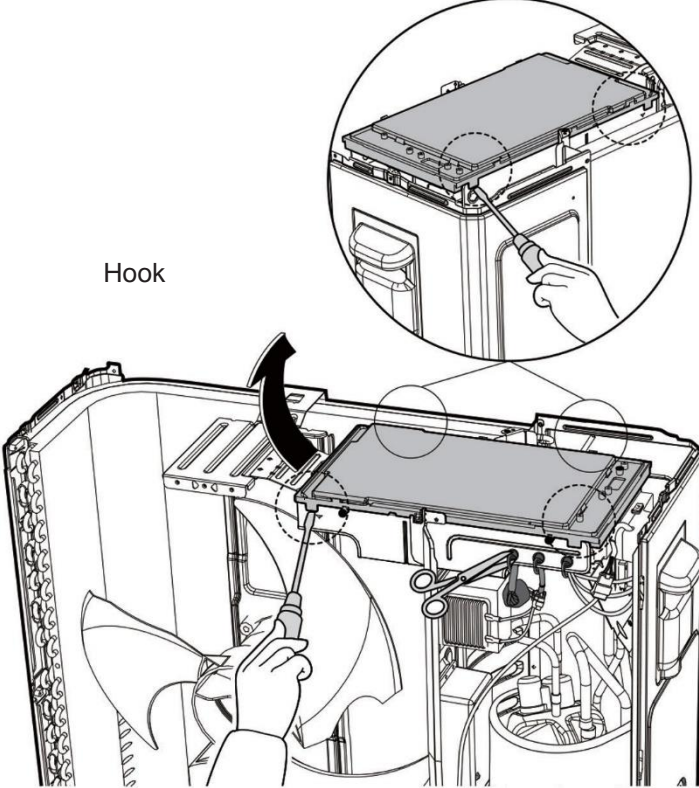
Procedure	Illustration
<p>1) Remove the nut securing the fan with a spanner (see CJ_ODU_INV_006).</p> <p>2) Remove the fan.</p>	 <p style="text-align: center;">CJ_ODU_INV_006</p>
<p>3) Unfix the hooks and then open the electronic control box cover (4 hooks) (see CJ_ODU_INV_007).</p>	 <p style="text-align: center;">CJ_ODU_INV_007</p>

Note: This section is for reference only. Actual unit appearance may vary.

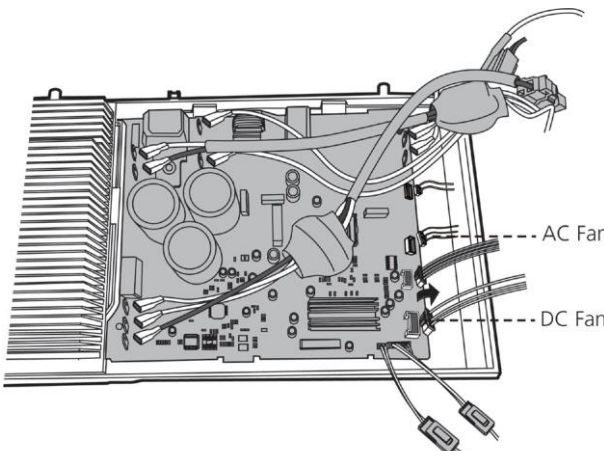
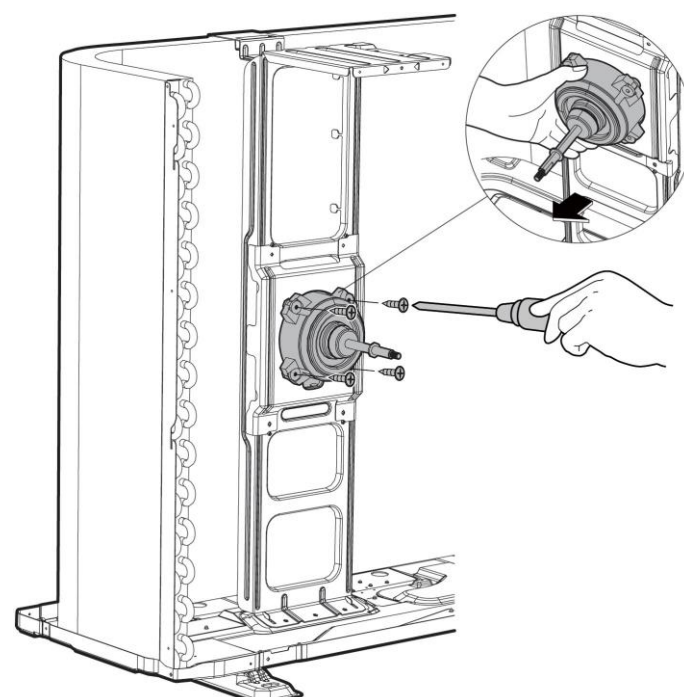
Procedure	Illustration
<p>4) Disconnect the connector for fan motor from the electronic control board (see CJ_ODU_INV_008).</p>	 <p style="text-align: center;">CJ_ODU_INV_008</p>
<p>5) Remove the fixing screws of the fan motor (4 screws) (see CJ_ODU_INV_009).</p> <p>6) Remove the fan motor.</p>	 <p style="text-align: center;">CJ_ODU_INV_009</p>

Note: This section is for reference only. Actual unit appearance may vary.

3. Electrical parts

Note: Remove the panel plate and fan assembly (refer to 1. Panel plate and 2. Fan assembly) before disassembling electrical parts.

KEX-09/12/18KTBO,KTCCO

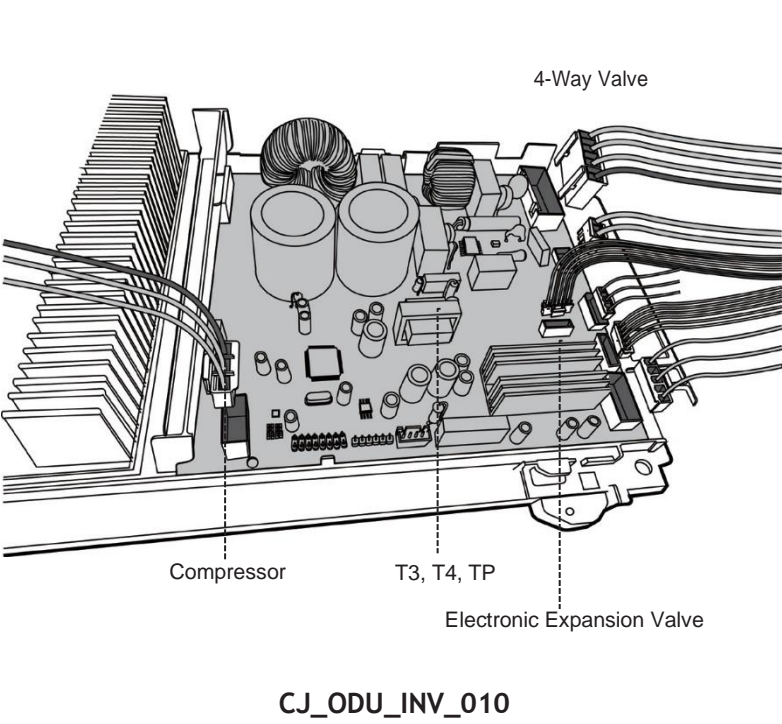
Procedure	Illustration
<ol style="list-style-type: none">1) Remove the connector for the compressor (see CJ_ODU_INV_010).2) Pull out the two blue wires connected with the four way valve (CJ_ODU_INV_010).3) Pull out connectors of the condenser coil temp. sensor(T3), outdoor ambient temp. sensor(T4) and discharge temp. sensor(TP) (CJ_ODU_INV_010).4) Disconnect the electronic expansion valve wire (CJ_ODU_INV_010).5) Then remove the electronic control box (see CJ_ODU_INV_010).	 <p>4-Way Valve</p> <p>Compressor</p> <p>T3, T4, TP</p> <p>Electronic Expansion Valve</p> <p>CJ_ODU_INV_010</p>

KEX-24KTBO

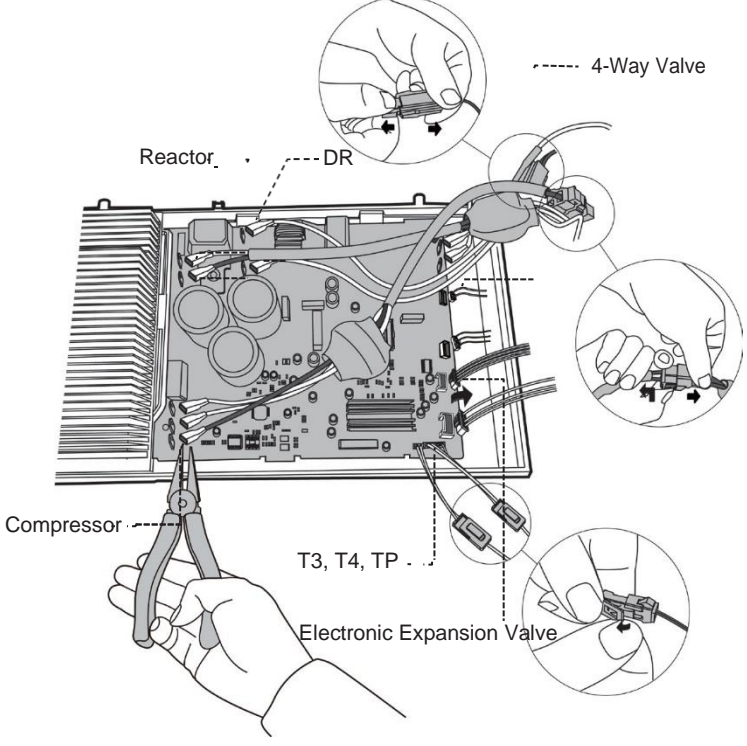
Procedure	Illustration
<ol style="list-style-type: none">1) Remove the connector for the compressor (see CJ_ODU_INV_011).2) Pull out the two blue wires connected with the four way valve (see CJ_ODU_INV_011).3) Pull out connectors of the condenser coil temp. sensor(T3), outdoor ambient temp. sensor(T4) and discharge temp. sensor(T5) (see CJ_ODU_INV_011).4) Disconnect the electronic expansion valve wire (see Fig CJ_ODU_INV_011).5) Remove the connector for the DR and reactor (see Fig CJ_ODU_INV_011).6) Then remove the electronic control box (see Fig CJ_ODU_INV_011).	 <p style="text-align: center;">CJ_ODU_INV_011</p>

Note: This section is for reference only. Actual unit appearance may vary.

4. Sound blanket

! WARNING: Recover refrigerant from the refrigerant circuit before remove the compressor.

Note: Remove the panel plate, electrical parts, and fan assembly (refer to 1. Panel plate, 2. Electrical parts, and 3. Fan assembly) before disassembling sound blanket.

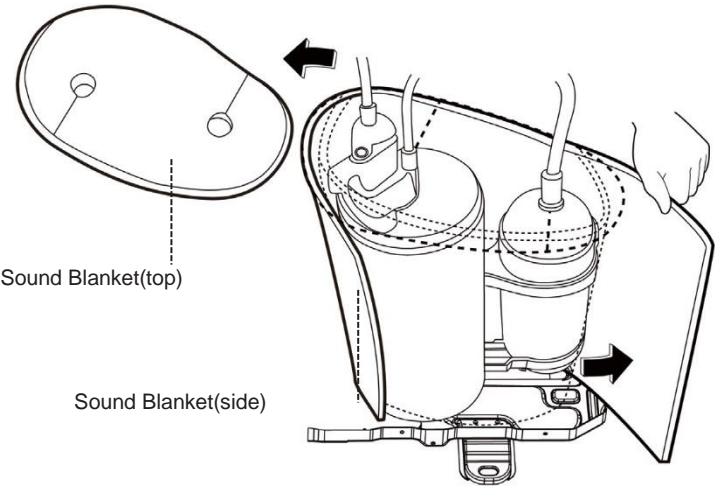
Procedure	Illustration
1) Remove the sound blanket (side and top) (see CJ_ODU_INV_012).	 <p data-bbox="901 1064 1141 1097">CJ_ODU_INV_012</p>

Note: This section is for reference only. Actual unit appearance may vary.

5. Four-way valve (for heat pump models)

!WARNING: Recover refrigerant from the refrigerant circuit before remove the four-way valve.

Note: Remove the panel plate, electrical parts, and fan assembly (refer to 1. Panel plate, 2. Electrical parts, and 3. Fan assembly) before disassembling four-way valve.

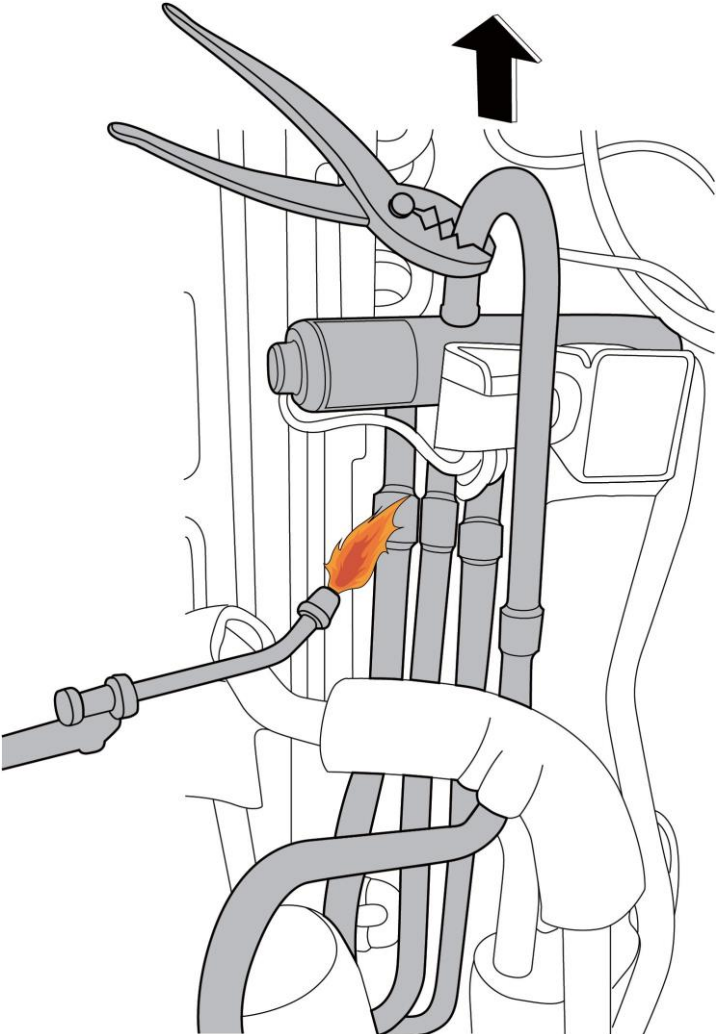
Procedure	Illustration
<p>1) Heat up the brazed parts and then detach the the four-way valve and the pipe (see CJ_ODU_INV_013).</p> <p>2) Remove the four-way valve assembly with pliers.</p>	 <p>CJ_ODU_INV_013</p>

Note: This section is for reference only. Actual unit appearance may vary.

6. Compressor

! WARNING: Recover refrigerant from the refrigerant circuit before remove the compressor.

Note: Remove the panel plate, electrical parts, and fan assembly (refer to 1. Panel plate, 2. Electrical parts, and 3. Fan assembly) before disassembling compressor.

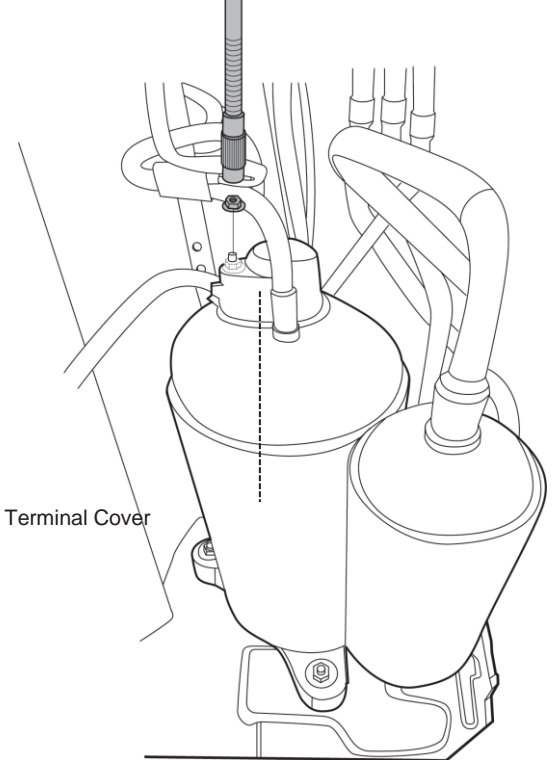
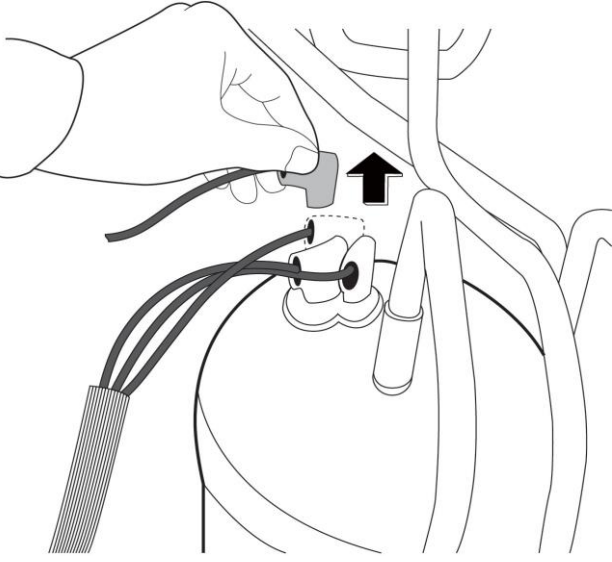
Procedure	Illustration
<p>1) Remove the flange nut of terminal cover and remove the terminal cover (see CJ_ODU_INV_014).</p>	 <p>The diagram shows a top-down view of the compressor assembly. A terminal cover is located on top of the compressor. A dashed vertical line indicates the removal path for the terminal cover. The label 'Terminal Cover' points to the cover. The compressor is connected to various pipes and electrical wires.</p> <p>CJ_ODU_INV_014</p>
<p>2) Disconnect the connectors (see CJ_ODU_INV_015).</p>	 <p>The diagram shows a close-up of a hand disconnecting an electrical connector from the compressor. The hand is pulling the connector away from the terminal block. A solid black arrow points upwards, indicating the direction of removal. The compressor and its associated pipes are visible in the background.</p> <p>CJ_ODU_INV_015</p>

Note: This section is for reference only. Actual unit appearance may vary.

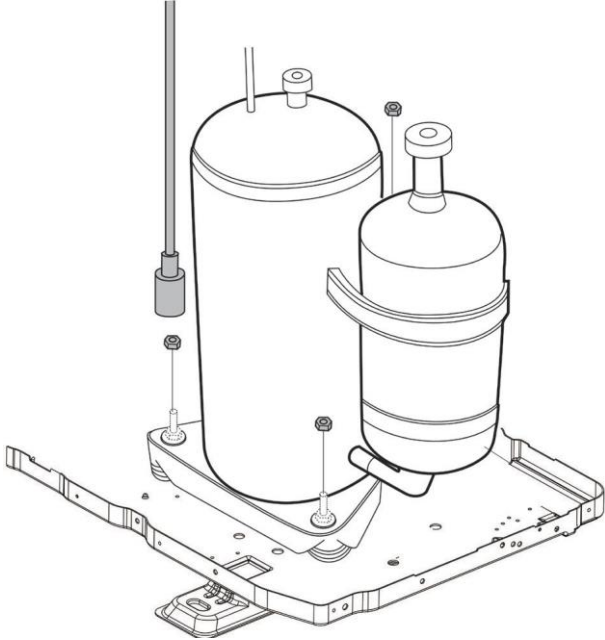
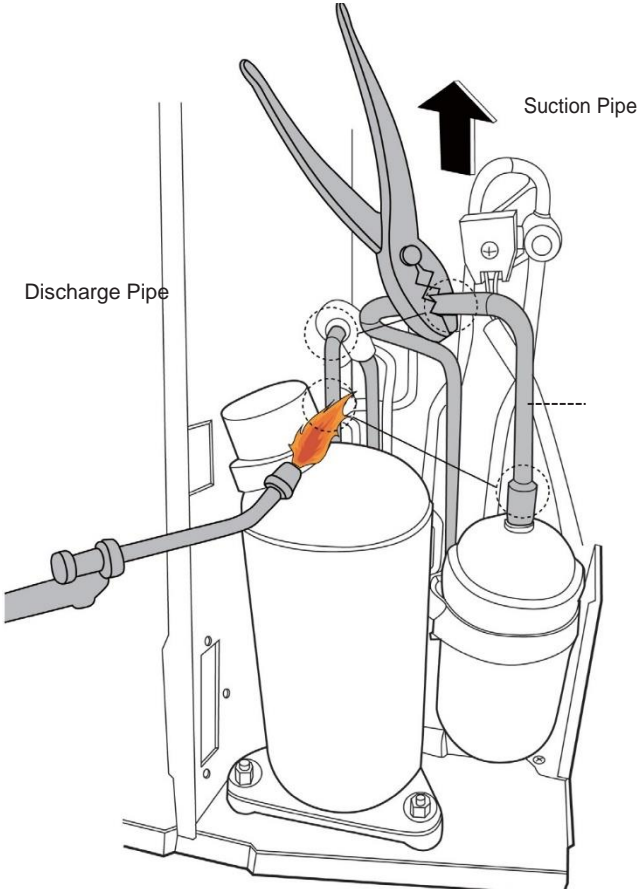
Procedure	Illustration
<p>3) Remove the hex nuts and washers securing the compressor, located on the bottom plate (see CJ_ODU_INV_016).</p>	 <p style="text-align: center;">CJ_ODU_INV_016</p>
<p>4) Heat up the brazed parts and then remove the the discharge pipe and the suction pipe (see CJ_ODU_INV_017).</p> <p>5) Lift the compressor from the base pan assembly with pliers.</p>	 <p style="text-align: center;">CJ_ODU_INV_017</p>

Note: This section is for reference only. Actual unit appearance may vary.

Troubleshooting

Contents

1.	Safety Caution	61
2.	General Troubleshooting	62
3.	Error Diagnosis and Troubleshooting Without Error Code	63
3.1	Remote maintenance	63
3.2	Field maintenance	64
4.	Quick Maintenance by Error Code	65
5.	Troubleshooting by Error Code	70
5.1	Common Check Procedures	70
5.2	E0/F4 (EEPROM parameter error).....	72
5.3	E1 (Indoor and outdoor unit communication error).....	73
5.4	E2 (Zero crossing detection error diagnosis and solution)	75
5.4	E3/F5 (Fan speed is operating outside of the normal range diagnosis and solution)	76
5.5	E4/E5/F1/F2/F3 (Open circuit or short circuit of temperature sensor diagnosis and solution)	78
5.6	E7 (Indoor PCB/Display board communication error)	79
5.7	EC (Refrigerant Leakage Detection diagnosis and solution)	80
5.8	F0(Overload current protection diagnosis and solution)	81
5.9	P0(IPM malfunction or IGBT over-strong current protection diagnosis and	



Contents

	solution)	82
5.10	P1(Over voltage or too low voltage protection diagnosis and solution)	83
5.11	P2(High temperature protection of IPM module diagnosis and solution).....	84
5.12	P4(Inverter compressor drive error diagnosis and solution).....	85

1. Safety Caution



Electricity remains in capacitors even when the power supply is off.
Ensure the capacitors are fully discharged before troubleshooting.

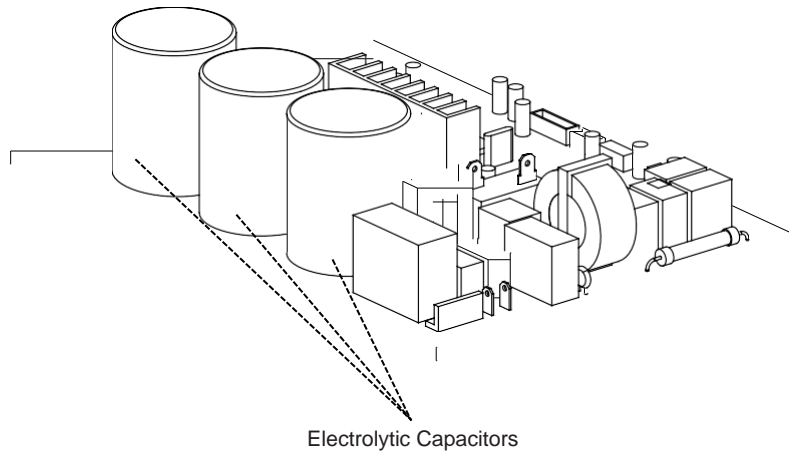

For other models, connect discharge resistance (approx. 100 Ω 40W) or a soldering iron plug between the positive and negative terminals of the electrolytic capacitor. The terminals are located on the bottom surface of the outdoor PCB.

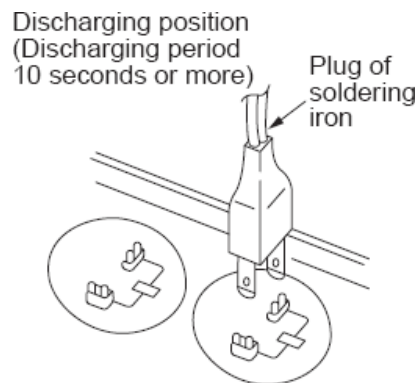

Note: This picture is for reference only. Actual appearances may vary.

2. General Troubleshooting

2.1 Error Display (Indoor Unit)

When the indoor unit encounters a recognized error, the operation lamp will flash in a corresponding series, the timer lamp may turn on or begin flashing, and an error code will be displayed. These error codes are described in the following table:

Operation lamp flashes	Timer lamp	LED Display	Error Information	Solution
1 time	OFF	E0	Indoor unit EEPROM parameter error	Page 72
2 times	OFF	E1	Indoor / outdoor units communication error	Page 73
3 times	OFF	E2	Zero-crossing signal detection error	Page 75
4 times	OFF	E3	The indoor fan speed is operating outside of the normal range	Page 76
5 times	OFF	E4	Indoor room temperature sensor T1 is in open circuit or has short circuited	Page 78
6 times	OFF	E5	Evaporator coil temperature sensor T2 is in open circuit or has short circuited	Page 78
9 times	OFF	E7	Indoor PCB /Display board communication error	Page 79
7 times	OFF	EC	Refrigerant leak detected	Page 80
1 time	ON	F0	Overload current protection	Page 81
2 times	ON	F1	Outdoor ambient temperature sensor T4 open circuit or short circuit	Page 78
3 times	ON	F2	Condenser coil temperature sensor T3 is in open circuit or has short circuited	Page 78
4 times	ON	F3	Compressor discharge temperature sensor TP open circuit or short circuit	Page 78
5 times	ON	F4	Outdoor unit EEPROM parameter error	Page 72
6 times	ON	F5	The outdoor fan speed is operating outside of the normal range	Page 76
1 time	FLASH	p0	IPM malfunction or IGBT over-strong current protection	Page 82
2 times	FLASH	p1	Over voltage or over low voltage protection	Page 83
3 times	FLASH	p2	High temperature protection of IPM module	Page 84
5 times	FLASH	p4	Inverter compressor drive error	Page 85

For other errors:

The display board may show a garbled code or a code undefined by the service manual. Ensure that this code is not a temperature reading.

Troubleshooting:

Test the unit using the remote control. If the unit does not respond to the remote, the indoor PCB requires replacement. If the unit responds, the display board requires replacement.

3. Error Diagnosis and Troubleshooting Without Error Code

WARNING

Be sure to turn off unit before any maintenance to prevent damage or injury.

3.1 Remote maintenance

SUGGESTION: When troubles occur, please check the following points with customers before field maintenance.

	Problem	Solution
1	Unit will not start	Page 66-67
2	The power switch is on but fans will not start	Page 66-67
3	The temperature on the display board cannot be set	Page 66-67
4	Unit is on but the wind is not cold(hot)	Page 66-67
5	Unit runs, but shortly stops	Page 66-67
6	The unit startup and stop frequently	Page 66-67
7	Unit runs continuously but insufficient cooling(heating)	Page 66-67
8	Cool can not change to heat	Page 66-67
9	Unit is noisy	Page 66-67

3.2 Field maintenance

	Problem	Solution
1	Unit will not start	Page 68-69
2	Compressor will not start but fans run	Page 68-69
3	Compressor and condenser (outdoor) fan will not start	Page 68-69
4	Evaporator (indoor) fan will not start	Page 68-69
5	Condenser (Outdoor) fan will not start	Page 68-69
6	Unit runs, but shortly stops	Page 68-69
7	Compressor short-cycles due to overload	Page 68-69
8	High discharge pressure	Page 68-69
9	Low discharge pressure	Page 68-69
10	High suction pressure	Page 68-69
11	Low suction pressure	Page 68-69
12	Unit runs continuously but insufficient cooling	Page 68-69
13	Too cool	Page 68-69
14	Compressor is noisy	Page 68-69
15	Horizontal louver can not revolve	Page 68-69

4. Quick Maintenance by Error Code

If you do not have the time to test whether specific parts are faulty, you can directly change the required parts according to the error code.

You can find the parts to replace by error code in the following table.

Part requiring replacement	Error Code								
	E0	E1	E3	E4	E5	E7	EC	F0	F1
Indoor PCB	✓	✓	✓	✓	✓	✓	✓	x	x
Outdoor PCB	x	✓	x	x	x	x	x	✓	✓
Reactor	x	✓	x	x	x	x	x	x	x
Indoor fan motor	x	x	✓	x	x	x	x	x	x
Outdoor fan motor	x	x	x	x	x	x	x	x	x
Temperature sensor	x	x	x	✓	✓	x	✓	x	✓
T2 Sensor	x	x	x	x	x	x	✓	x	x
Additional refrigerant	x	x	x	x	x	x	x	x	x
Compressor	x	x	x	x	x	x	x	✓	x
IPM board	x	x	x	x	x	x	x	x	x
Outdoor unit	x	x	x	x	x	x	x	✓	x
Display board	x	x	x	x	x	✓	x	x	x

Part requiring replacement	Error Code							
	R1	F3	F4	F5	P0	P1	P2	P4
Indoor PCB	x	x	x	x	x	x	x	x
Outdoor PCB	✓	✓	✓	✓	✓	✓	✓	✓
Reactor	x	x	x	x	x	✓	x	x
Indoor fan motor	x	x	x	x	x	x	x	x
Outdoor fan motor	x	x	x	✓	x	x	x	x
Temperature sensor	✓	✓	x	x	x	x	x	x
T2 Sensor	x	x	x	x	x	x	x	x
Additional refrigerant	x	x	x	x	x	x	x	x
Compressor	x	x	x	x	✓	x	x	✓
IPM board	x	x	x	x	✓	✓	x	✓
Outdoor unit	x	x	x	x	x	x	x	x

1. Remote Maintenance		Electrical Circuit		Refrigerant Circuit			
Possible causes of trouble							
Unit will not start	☆	☆					
The power switch is on but fans will not start		☆	☆				
The temperature on the display board cannot be set							
Unit is on but the wind is not cold(hot)							
Unit runs, but shortly stops			☆	☆			
The unit starts up and stops frequently			☆				
Unit runs continuously but insufficient cooling(heating)							
Cool can not change to heat							
Unit is noisy							
Test method / remedy		Power failure					
		The main power tripped					
		Loose connections	☆	☆			
		Faulty transformer	☆	☆			
		The voltage is too high or too low	☆				
		The remote control is powered off		☆			
		Broken remote control		☆			
		Dirty air filter					
		Dirty condenser fins					
		The setting temperature is higher/lower than the room's(cooling/heating)					
		The ambient temperature is too high/low when the mode is cooling/heating					
		Fan mode					
		SILENCE function is activated(optional function)					
		Frosting and defrosting frequently					

Check heat load			☆							Heavy load condition
Tighten bolts or screws	☆									Loosen hold down bolts and / or screws
Close all the windows and doors			☆							Bad airproof
Remove the obstacles			☆	☆						The air inlet or outlet of either unit is blocked
Reconnect the power or press ON/OFF button on remote control to restart								☆		Interference from cell phone towers and remote boosters
Remove them	☆									Shipping plates remain attached

Others

5. Troubleshooting by Error Code

5.1 Common Check Procedures

5.1.1 Temperature Sensor Check

Disconnect the temperature sensor from PCB, measure the resistance value with a tester.

Temperature Sensors.

Room temp.(T1) sensor,

Indoor coil temp.(T2) sensor,

Outdoor coil temp.(T3) sensor,

Outdoor ambient temp.(T4) sensor,

Compressor discharge temp.(Tp) sensor.

Measure the resistance value of each winding by using the multi-meter.

5.1.2 Compressor checking

Measure the resistance value of each winding by using the tester.

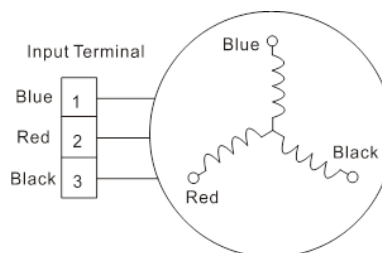

Position	Resistance Value		
	KSK89D53UEZ	KSM135D23UFZ	KTF235D22UMT
Blue - Red	2.35 \wedge (20°C/68°F)	1.28 \wedge (20°C/68°F)	0.75 \wedge (20°C/68°F)
Blue - Black			
Red - Blue			



5.1.3 IPM Continuity Check

Turn off the power, let the large capacity electrolytic capacitors discharge completely, and dismount the IPM. Use a digital tester to measure the resistance between P and UVWN; UVW and N.

Digital tester		Normal resistance value	Digital tester		Normal resistance value
(+)Red	(-)Black		(+)Red	(-)Black	
P	N	∞ (Several M \wedge)	U	N	∞ (Several M \wedge)
	U		V		
	V		W		
	W		(+)Red		

5.2 E0/F4 (EEPROM parameter error)

Description: Indoor or outdoor PCB main chip does not receive feedback from EEPROM chip.

Recommended parts to prepare:

- Faulty indoor PCB
- Faulty outdoor PCB

Troubleshooting and repair:

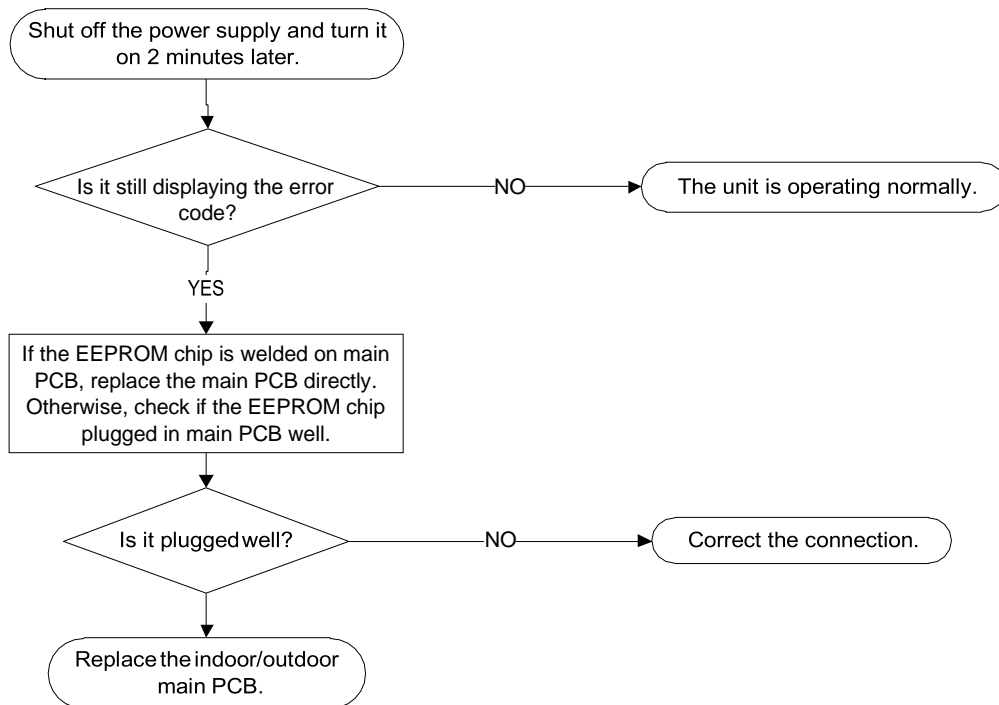

Remarks:

The location of the EEPROM chip on the indoor and outdoor PCB is shown in the following two images:

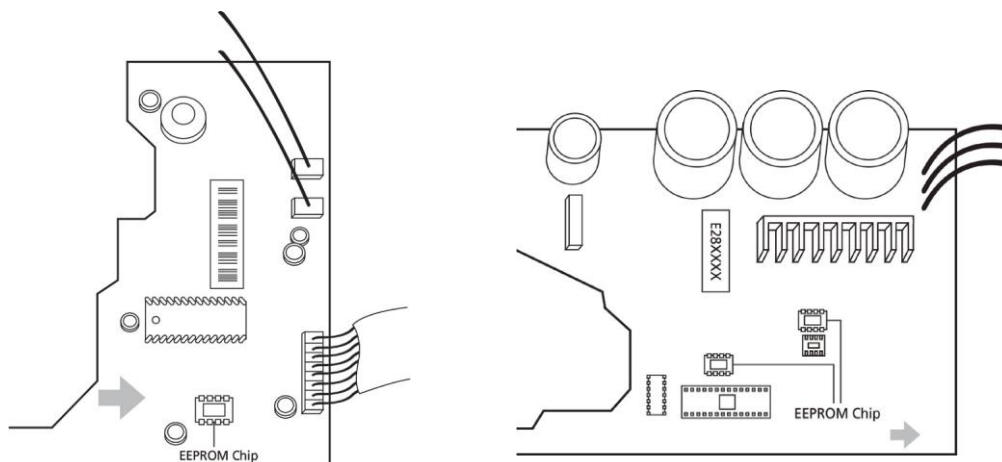

Note: These images are for reference only.

5.3 E1 (Indoor and outdoor unit communication error)

Description: The indoor unit has not received feedback from the outdoor unit for 110 seconds, four consecutive times.

Recommended parts to prepare:

- Faulty indoor PCB
- Faulty outdoor PCB
- Faulty reactor

Troubleshooting and repair:

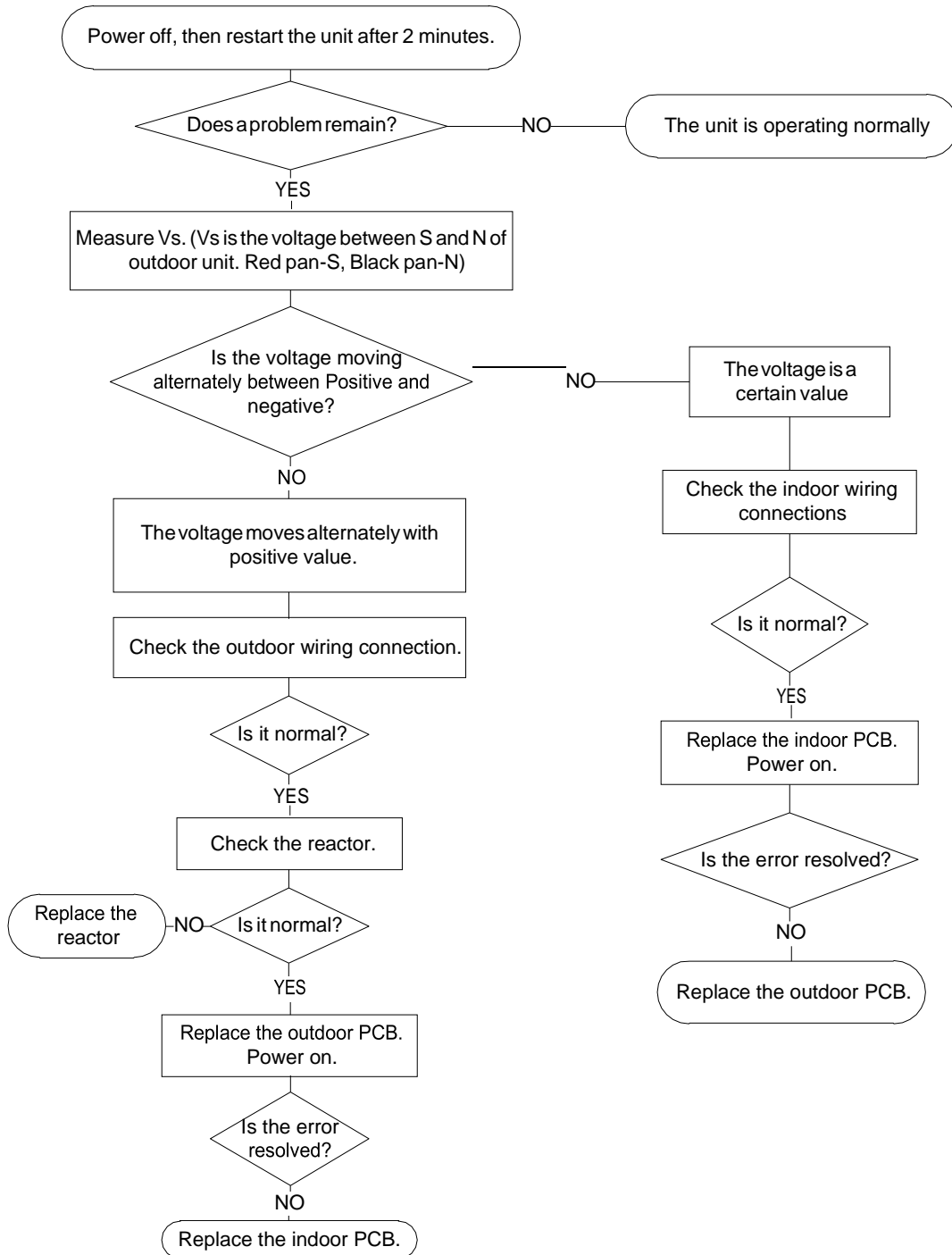

Remarks:

- Use a multimeter to test the resistance of the reactor which does not connect with capacitor.
- The normal value should be around zero ohm. Otherwise, the reactor must have malfunction.



5.4 E2 (Zero crossing detection error diagnosis and solution)

Description: When PCB does not receive zero crossing signal feedback for 4 minutes or the zero crossing signal time interval is abnormal.

Recommended parts to prepare:

- Connection mistake
- Faulty PCB

Troubleshooting and repair:

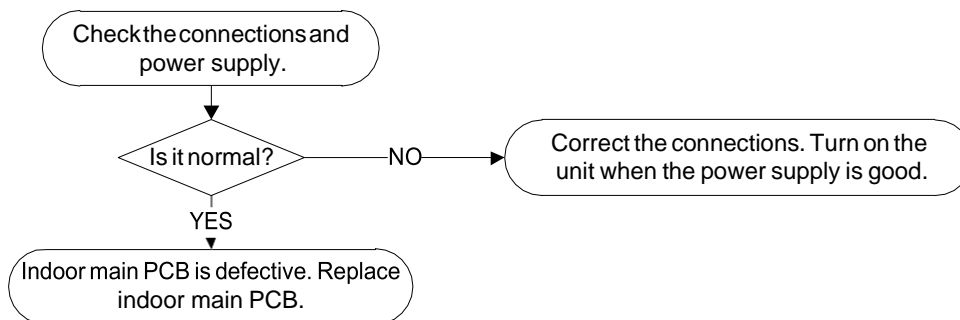

5.5 E3/F5 (Fan speed is operating outside of the normal range)

Description: When the indoor fan speed keeps too low (300RPM) for certain time, the unit will stop and the LED will display the failure(E3). When the outdoor fan speed registers below 200RPM or over 1500RPM for an extended period of time, the unit will stop and the LED will display the failure(F5).

Recommended parts to prepare:

- Wiring mistake
- Faulty fan assembly
- Faulty fan motor
- Faulty PCB

Troubleshooting and repair:

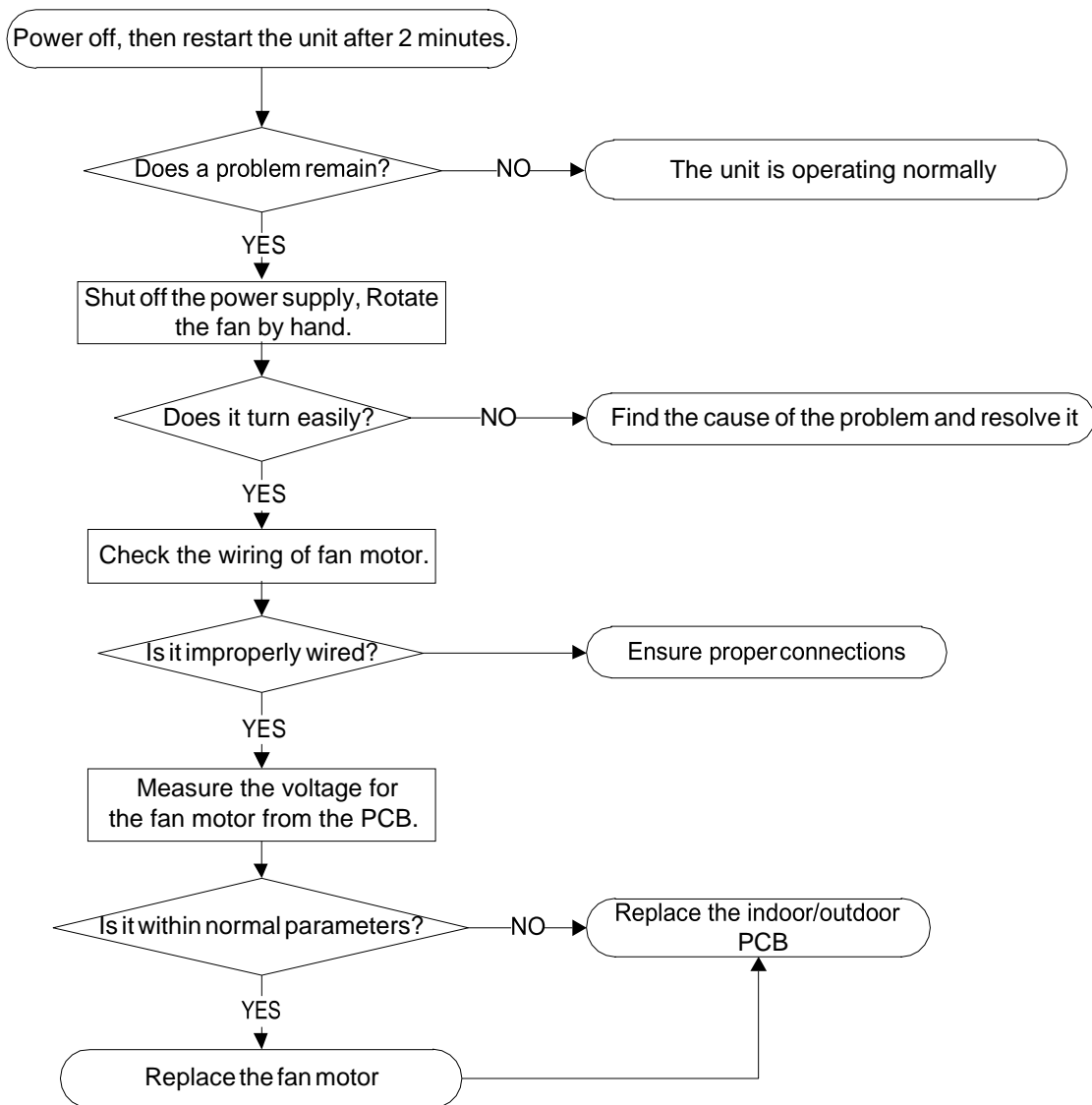

Index:

1. Indoor or Outdoor DC Fan Motor(control chip is in fan motor)

Power on and when the unit is in standby, measure the voltage of pin1-pin3, pin4-pin3 in fan motor connector. If the value of the voltage is not in the range showing in below table, the PCB must has problems and need to be replaced.

- DC motor voltage input and output (voltage: 220-240V~):

No.	Color	Signal	Voltage
1	Red	Vs/Vm	280V~380V
2	---	---	---
3	Black	GND	0V
4	White	Vcc	14-17.5V
5	Yellow	Vsp	0~5.6V
6	Blue	FG	14-17.5V

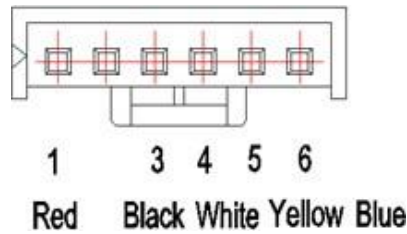

2. Indoor AC Fan Motor

Power on and set the unit running in fan mode at high fan speed. After running for 15 seconds, measure the voltage of pin1 and pin2. If the value of the voltage is less than 100V(208~240V power supply) or 50V(115V power supply), the PCB must has problems and need to be replaced.

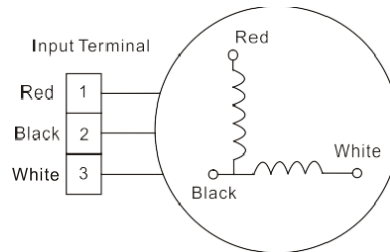

5.6 E4/E5/F1/F2/F3 (Open circuit or short circuit of temperature sensor diagnosis and solution)

Description: If the sampling voltage is lower than 0.06V or higher than 4.94V, the LED will display the failure.

Recommended parts to prepare:

- Wiring mistake
- Faulty sensor
- Faulty PCB

Troubleshooting and repair:

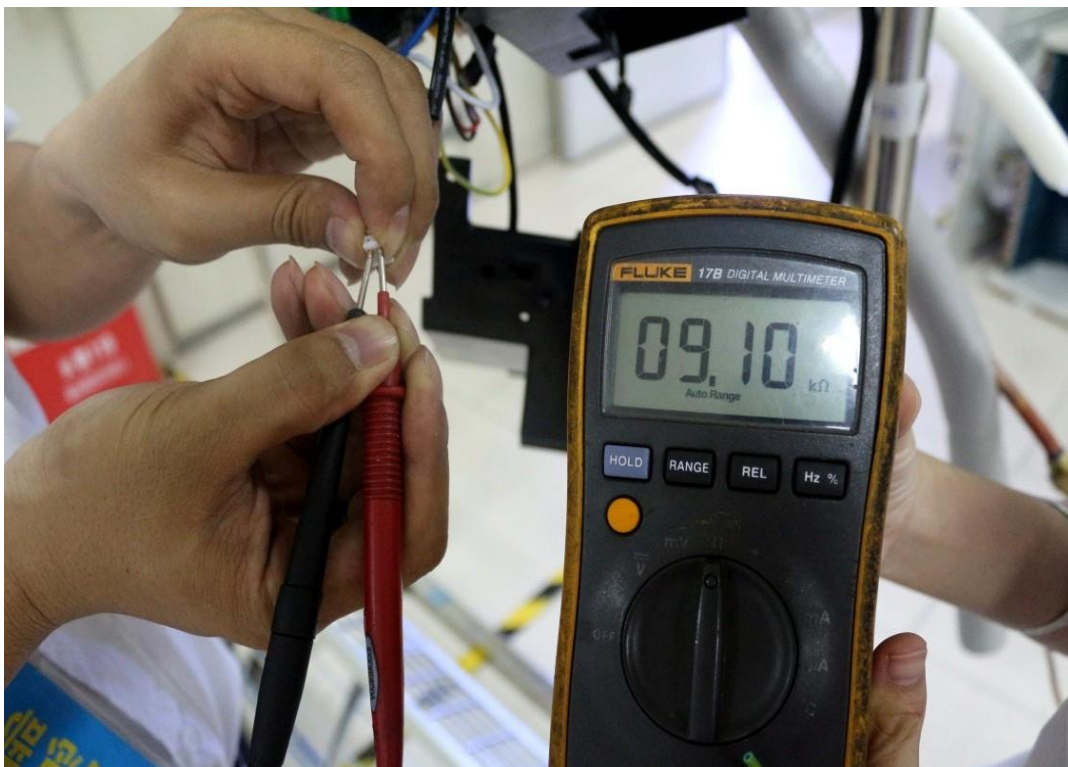
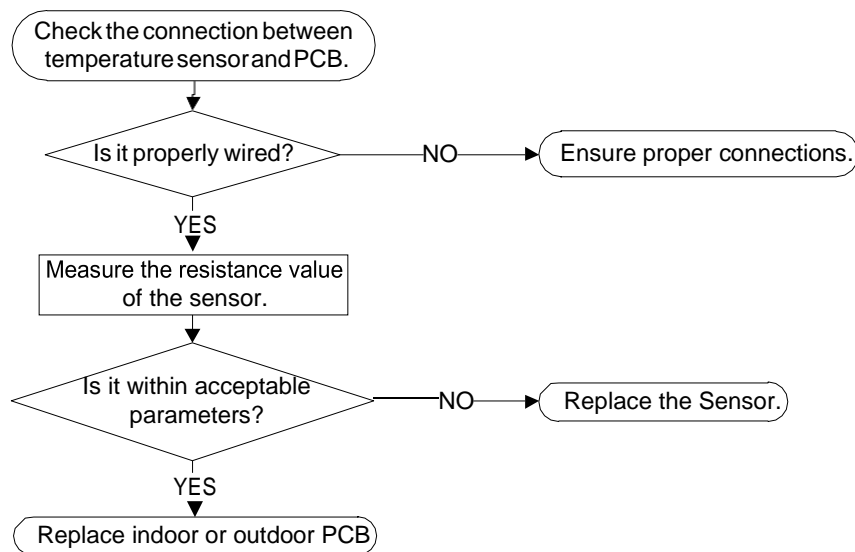

5.7 E7 (Indoor PCB /Display board communication error)

Description: Indoor PCB does not receive feedback from Display board for 120 seconds.

Recommended parts to prepare:

- Wiring mistake
- Faulty PCB
- Display board malfunction

Troubleshooting and repair:

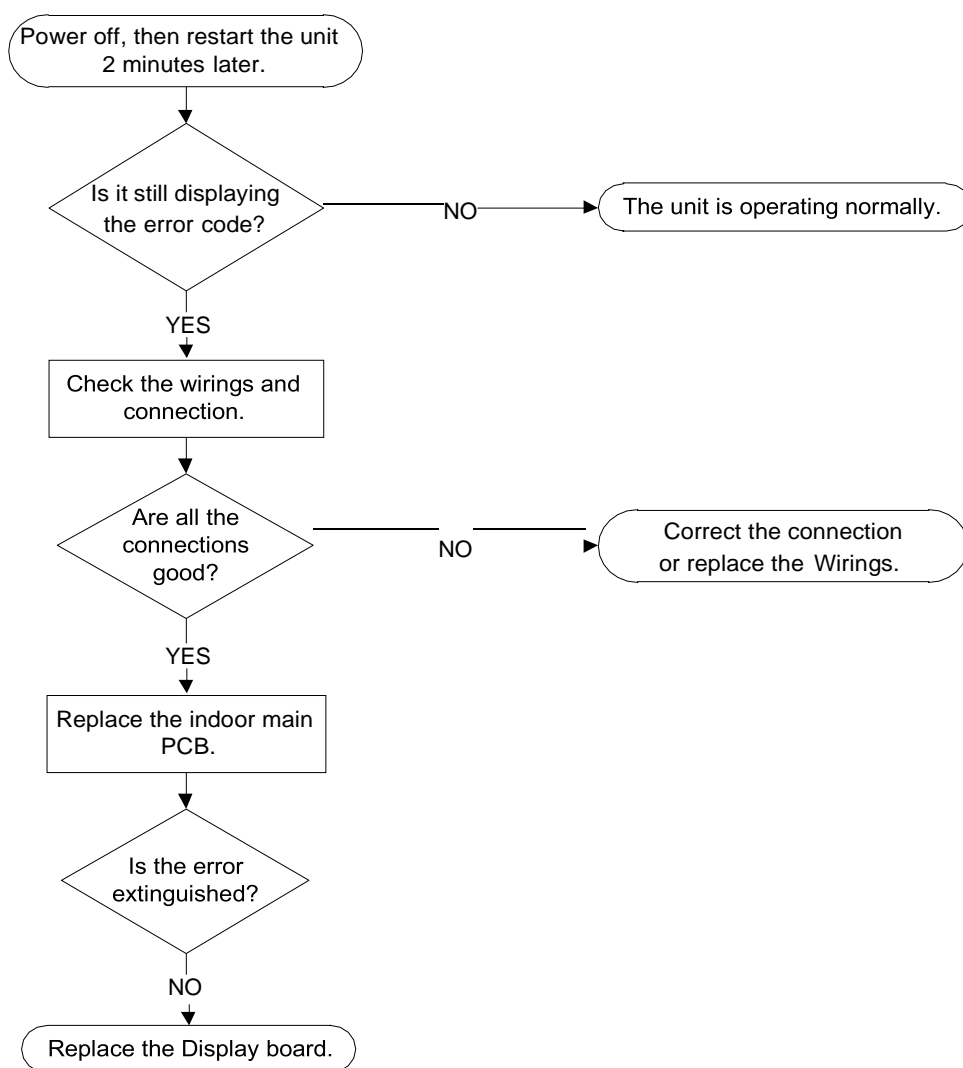

5.8 EC (Refrigerant Leakage Detection diagnosis and solution)

Description: Define the evaporator coil temp.T2 of the compressor just starts running as Tcool.

In the beginning 8 minutes after the compressor starts up, if $T2 < T_{cool} - 1^{\circ}\text{C}$ does not keep continuous 4 seconds and compressor running frequency higher than 50Hz does not keep continuous 3 minutes, and this situation happens 3 times, the display area will show “EC” and AC will turn off.

Recommended parts to prepare:

- Faulty T2 sensor
- Faulty indoor PCB
- System problems, such as leakage or blockages

Troubleshooting and repair:

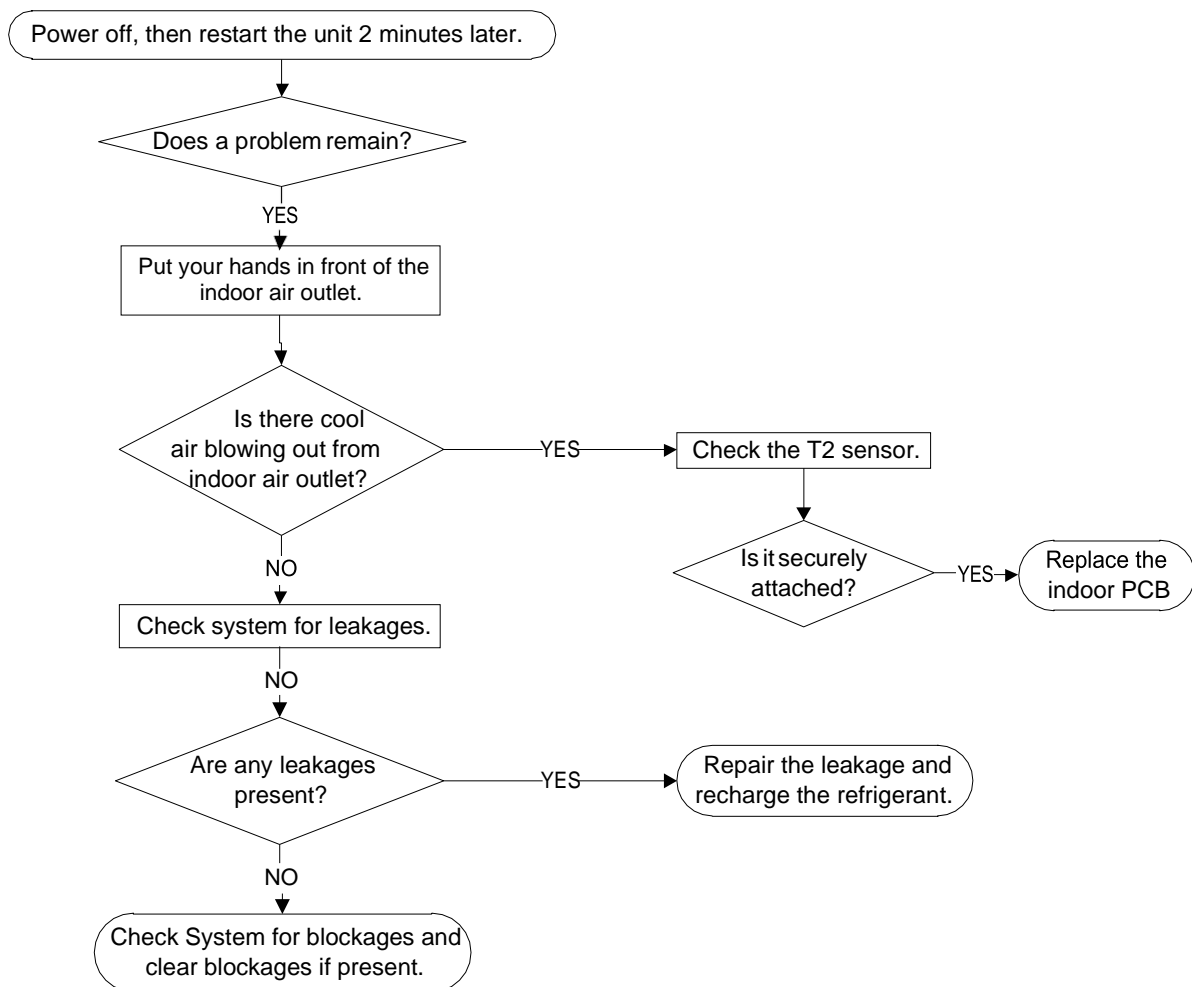

5.9 F0(Overload current protection diagnosis and solution)

Description: An abnormal current rise is detected by checking the specified current detection circuit.

Recommended parts to prepare:

- Power supply problems.
- System blockage
- Faulty PCB
- Wiring mistake
- Compressor malfunction

Troubleshooting and repair:

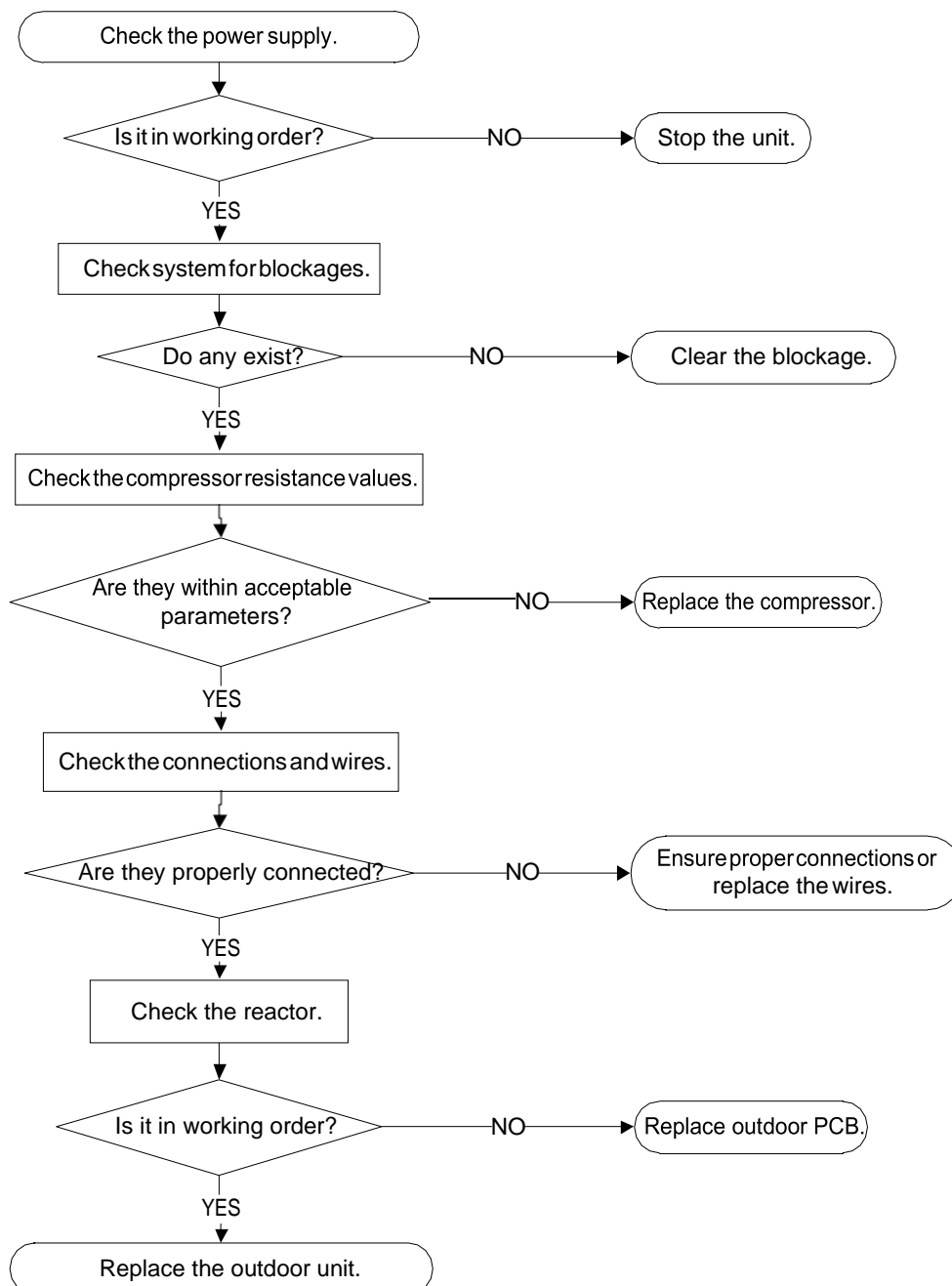

5.10 P0(IPM malfunction or IGBT over-strong current protection diagnosis and solution)

Description: When the voltage signal the IPM sends to the compressor drive chip is abnormal, the display LED shows “P0” and the AC turn off.

Recommended parts to prepare:

- Wiring mistake
- IPM malfunction
- Faulty outdoor fan assembly
- Compressor malfunction
- Faulty outdoor PCB

Troubleshooting and repair:

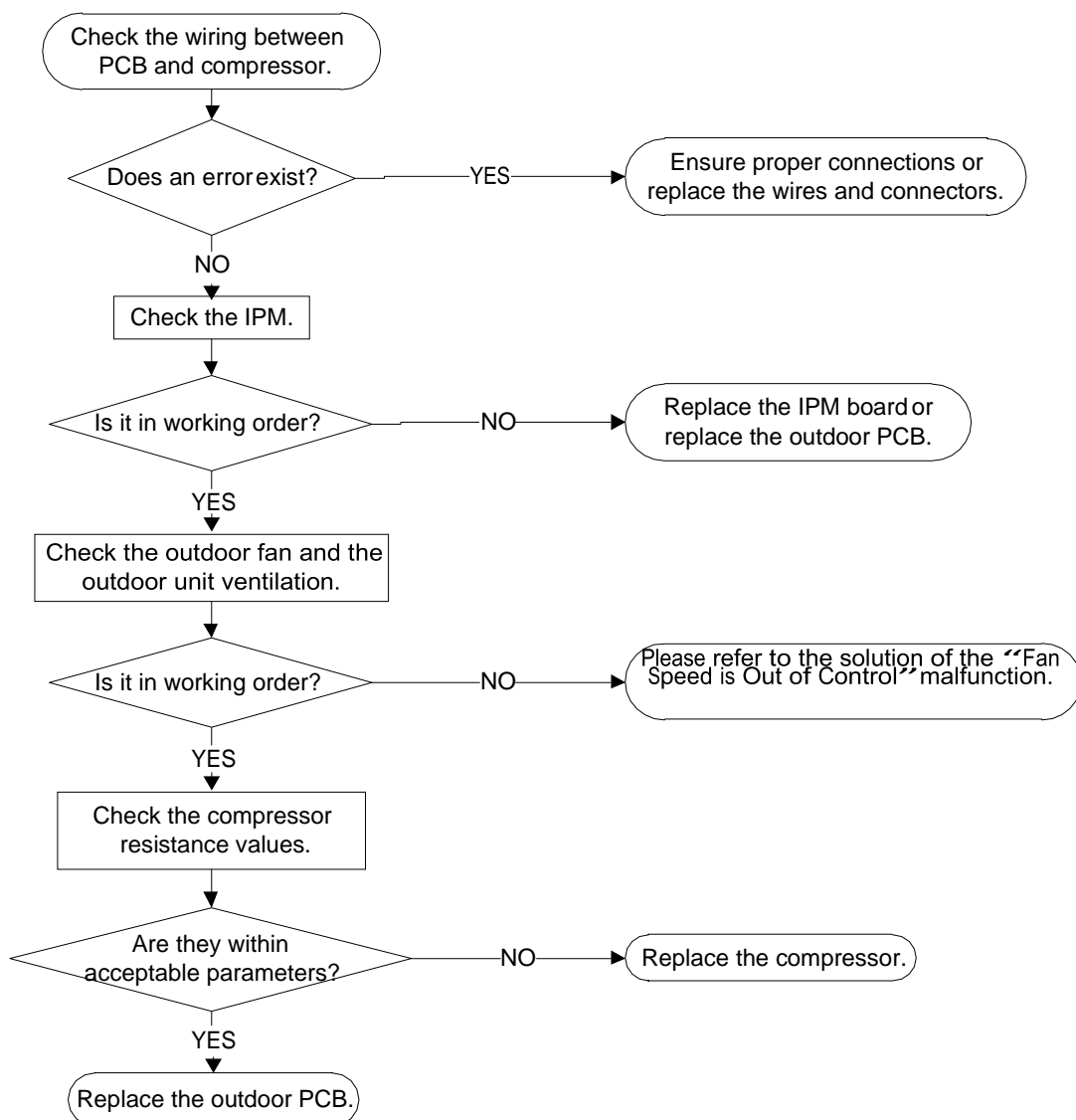

5.11 P1(Over voltage or too low voltage protection diagnosis and solution)

Description: Abnormal increases or decreases in voltage are detected by checking the specified voltage detection circuit.

Recommended parts to prepare:

- Power supply issues
- System leakage or blockage
- Faulty PCB

Troubleshooting and repair:

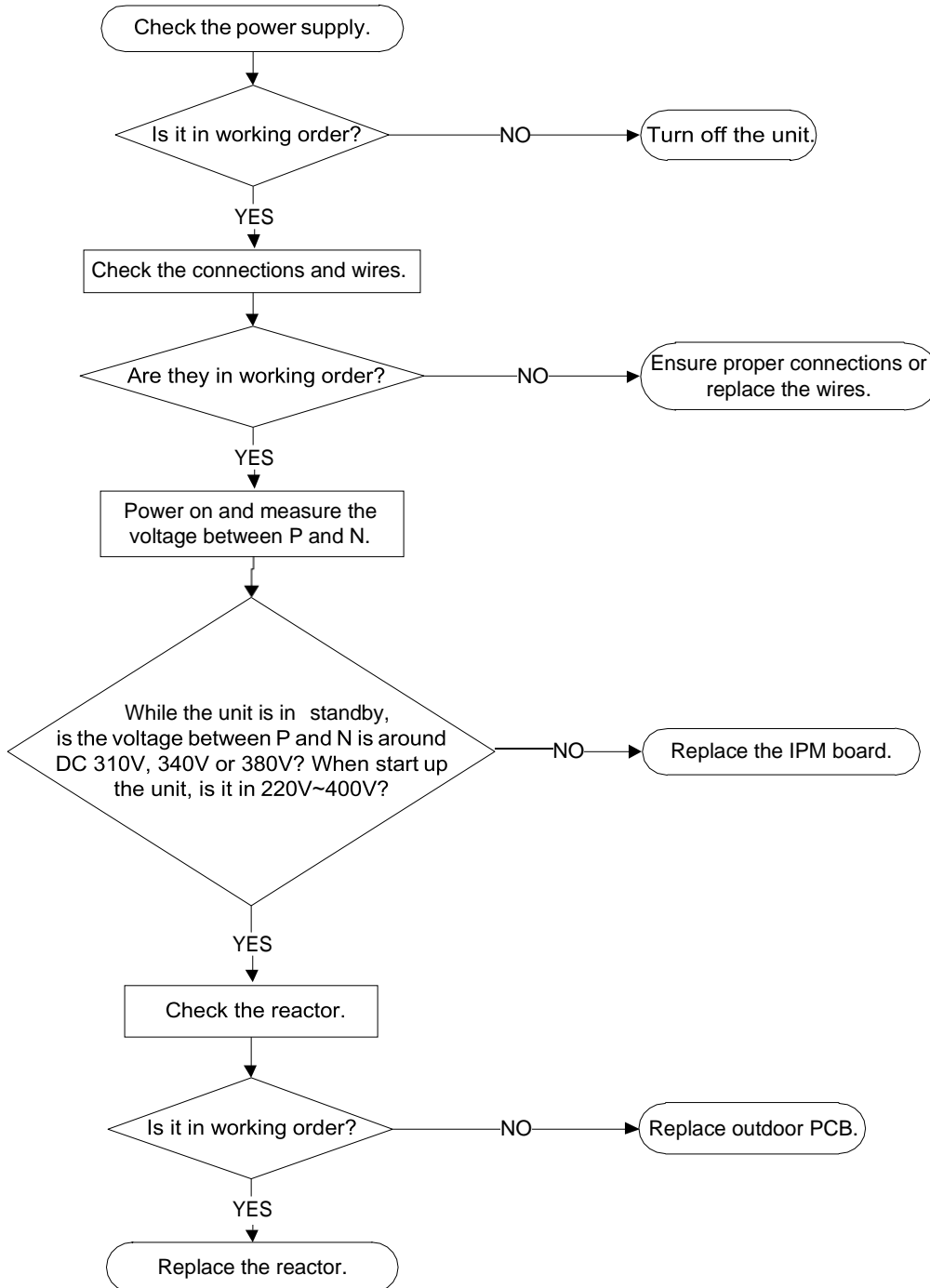

5.12 P2(High temperature protection of IPM module diagnosis and solution)

Description: If the temperature of IPM module is higher than setting value, the LED displays this failure code.

Recommended parts to prepare:

- Faulty PCB
- Connection problems

Troubleshooting and repair:

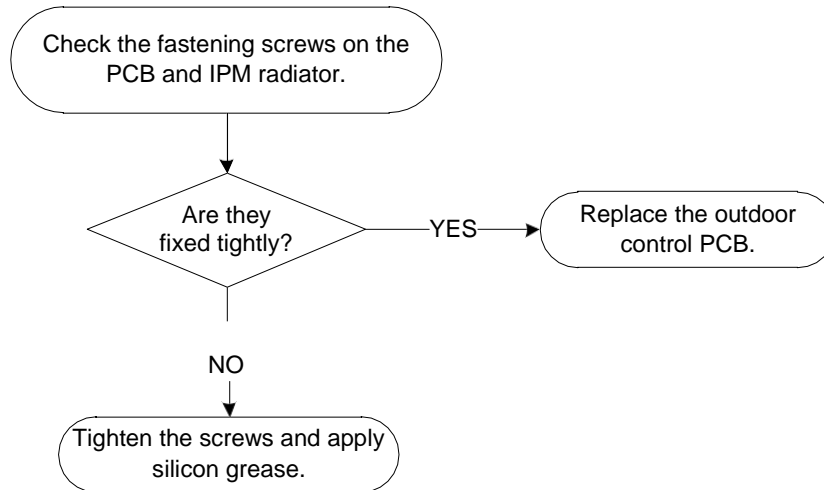

5.13 P4(Inverter compressor drive error diagnosis and solution)

Description: An abnormal inverter compressor drive is detected by a special detection circuit, including communication signal detection, voltage detection, compressor rotation speed signal detection and so on.

Recommended parts to prepare:

- Wiring mistake
- IPM malfunction
- Faulty outdoor fan assembly
- Compressor malfunction
- Faulty outdoor PCB

Troubleshooting and repair:

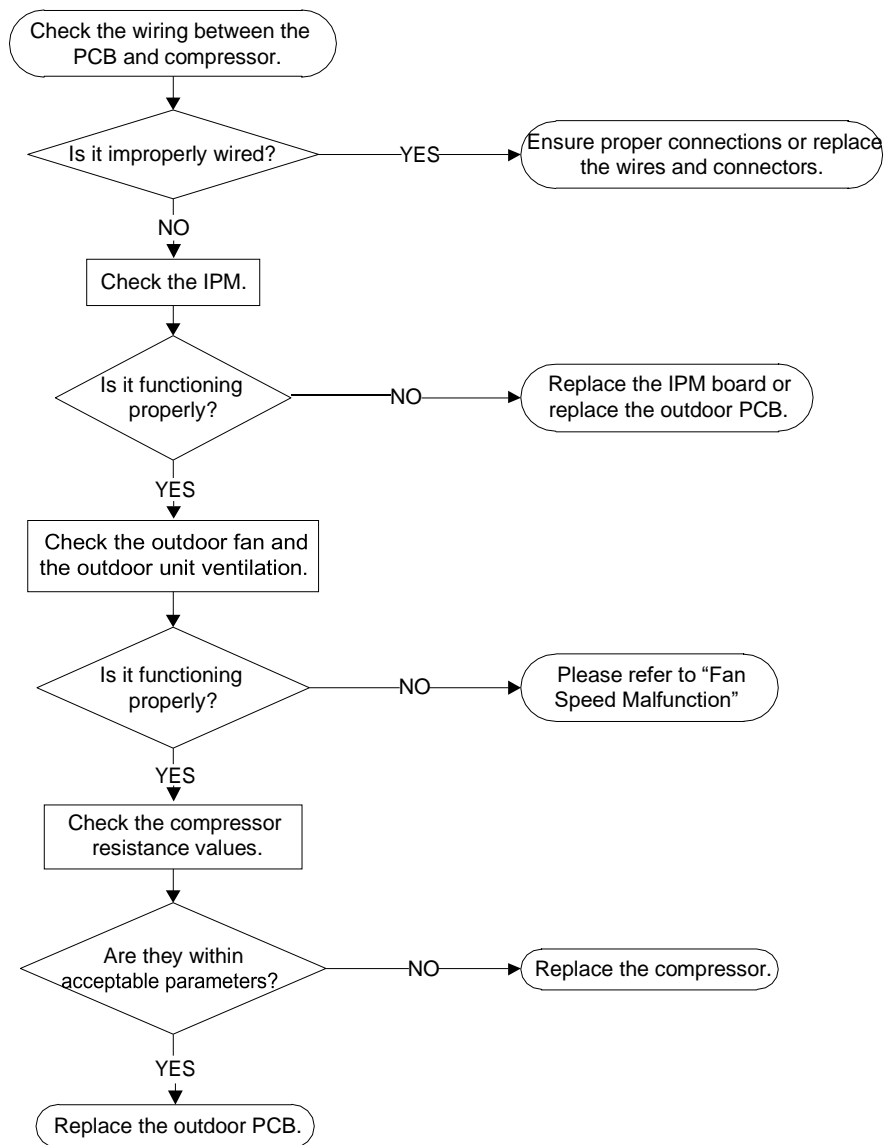

Appendix

Contents

i)	Temperature Sensor Resistance Value Table for T1, T2, T3, and T4 (°C - K). 87
ii)	Temperature Sensor Resistance Value Table for TP (°C - K) 88
iii)	Pressure On Service Port 89

i) Temperature Sensor Resistance Value Table for T1,T2,T3 and T4 (°C - K)

°C	°F	K Ohm	°C	°F	K Ohm	°C	°F	K Ohm	°C	°F	K Ohm
-20	-4	115.266	20	68	12.6431	60	140	2.35774	100	212	0.62973
-19	-2	108.146	21	70	12.0561	61	142	2.27249	101	214	0.61148
-18	0	101.517	22	72	11.5	62	144	2.19073	102	216	0.59386
-17	1	96.3423	23	73	10.9731	63	145	2.11241	103	217	0.57683
-16	3	89.5865	24	75	10.4736	64	147	2.03732	104	219	0.56038
-15	5	84.219	25	77	10	65	149	1.96532	105	221	0.54448
-14	7	79.311	26	79	9.55074	66	151	1.89627	106	223	0.52912
-13	9	74.536	27	81	9.12445	67	153	1.83003	107	225	0.51426
-12	10	70.1698	28	82	8.71983	68	154	1.76647	108	226	0.49989
-11	12	66.0898	29	84	8.33566	69	156	1.70547	109	228	0.486
-10	14	62.2756	30	86	7.97078	70	158	1.64691	110	230	0.47256
-9	16	58.7079	31	88	7.62411	71	160	1.59068	111	232	0.45957
-8	18	56.3694	32	90	7.29464	72	162	1.53668	112	234	0.44699
-7	19	52.2438	33	91	6.98142	73	163	1.48481	113	235	0.43482
-6	21	49.3161	34	93	6.68355	74	165	1.43498	114	237	0.42304
-5	23	46.5725	35	95	6.40021	75	167	1.38703	115	239	0.41164
-4	25	44	36	97	6.13059	76	169	1.34105	116	241	0.4006
-3	27	41.5878	37	99	5.87359	77	171	1.29078	117	243	0.38991
-2	28	39.8239	38	100	5.62961	78	172	1.25423	118	244	0.37956
-1	30	37.1988	39	102	5.39689	79	174	1.2133	119	246	0.36954
0	32	35.2024	40	104	5.17519	80	176	1.17393	120	248	0.35982
1	34	33.3269	41	106	4.96392	81	178	1.13604	121	250	0.35042
2	36	31.5635	42	108	4.76253	82	180	1.09958	122	252	0.3413
3	37	29.9058	43	109	4.5705	83	181	1.06448	123	253	0.33246
4	39	28.3459	44	111	4.38736	84	183	1.03069	124	255	0.3239
5	41	26.8778	45	113	4.21263	85	185	0.99815	125	257	0.31559
6	43	25.4954	46	115	4.04589	86	187	0.96681	126	259	0.30754
7	45	24.1932	47	117	3.88673	87	189	0.93662	127	261	0.29974
8	46	22.5662	48	118	3.73476	88	190	0.90753	128	262	0.29216
9	48	21.8094	49	120	3.58962	89	192	0.8795	129	264	0.28482
10	50	20.7184	50	122	3.45097	90	194	0.85248	130	266	0.2777
11	52	19.6891	51	124	3.31847	91	196	0.82643	131	268	0.27078
12	54	18.7177	52	126	3.19183	92	198	0.80132	132	270	0.26408
13	55	17.8005	53	127	3.07075	93	199	0.77709	133	271	0.25757
14	57	16.9341	54	129	2.95896	94	201	0.75373	134	273	0.25125
15	59	16.1156	55	131	2.84421	95	203	0.73119	135	275	0.24512
16	61	15.3418	56	133	2.73823	96	205	0.70944	136	277	0.23916
17	63	14.6181	57	135	2.63682	97	207	0.68844	137	279	0.23338
18	64	13.918	58	136	2.53973	98	208	0.66818	138	280	0.22776
19	66	13.2631	59	138	2.44677	99	210	0.64862	139	282	0.22231

ii) Temperature Sensor Resistance Value Table for TP (°C - K)

°C	°F	K Ohm	°C	°F	K Ohm	°C	°F	K Ohm	°C	°F	K Ohm
-20	-4	542.7	20	68	68.66	60	140	13.59	100	212	3.702
-19	-2	511.9	21	70	65.62	61	142	13.11	101	214	3.595
-18	0	483	22	72	62.73	62	144	12.65	102	216	3.492
-17	1	455.9	23	73	59.98	63	145	12.21	103	217	3.392
-16	3	430.5	24	75	57.37	64	147	11.79	104	219	3.296
-15	5	406.7	25	77	54.89	65	149	11.38	105	221	3.203
-14	7	384.3	26	79	52.53	66	151	10.99	106	223	3.113
-13	9	363.3	27	81	50.28	67	153	10.61	107	225	3.025
-12	10	343.6	28	82	48.14	68	154	10.25	108	226	2.941
-11	12	325.1	29	84	46.11	69	156	9.902	109	228	2.86
-10	14	307.7	30	86	44.17	70	158	9.569	110	230	2.781
-9	16	291.3	31	88	42.33	71	160	9.248	111	232	2.704
-8	18	275.9	32	90	40.57	72	162	8.94	112	234	2.63
-7	19	261.4	33	91	38.89	73	163	8.643	113	235	2.559
-6	21	247.8	34	93	37.3	74	165	8.358	114	237	2.489
-5	23	234.9	35	95	35.78	75	167	8.084	115	239	2.422
-4	25	222.8	36	97	34.32	76	169	7.82	116	241	2.357
-3	27	211.4	37	99	32.94	77	171	7.566	117	243	2.294
-2	28	200.7	38	100	31.62	78	172	7.321	118	244	2.233
-1	30	190.5	39	102	30.36	79	174	7.086	119	246	2.174
0	32	180.9	40	104	29.15	80	176	6.859	120	248	2.117
1	34	171.9	41	106	28	81	178	6.641	121	250	2.061
2	36	163.3	42	108	26.9	82	180	6.43	122	252	2.007
3	37	155.2	43	109	25.86	83	181	6.228	123	253	1.955
4	39	147.6	44	111	24.85	84	183	6.033	124	255	1.905
5	41	140.4	45	113	23.89	85	185	5.844	125	257	1.856
6	43	133.5	46	115	22.89	86	187	5.663	126	259	1.808
7	45	127.1	47	117	22.1	87	189	5.488	127	261	1.762
8	46	121	48	118	21.26	88	190	5.32	128	262	1.717
9	48	115.2	49	120	20.46	89	192	5.157	129	264	1.674
10	50	109.8	50	122	19.69	90	194	5	130	266	1.632
11	52	104.6	51	124	18.96	91	196	4.849			
12	54	99.69	52	126	18.26	92	198	4.703			
13	55	95.05	53	127	17.58	93	199	4.562			
14	57	90.66	54	129	16.94	94	201	4.426			
15	59	86.49	55	131	16.32	95	203	4.294			
16	61	82.54	56	133	15.73	96	205	4.167			
17	63	78.79	57	135	15.16	97	207	4.045			
18	64	75.24	58	136	14.62	98	208	3.927			
19	66	71.86	59	138	14.09	99	210	3.812			

iii) Pressure On Service Port(R32)

Cooling chart:

°F (°C)	ODT		0(-17)	5(-15)	15 (9.44)	45 (7.22)	75 (23.89)	85 (29.44)	95 (35)	105 (40.56)	115 (46.11)	120 (48.89)
	IDT											
BAR	70/59		6.5	6.6	7.4	8.2	8.4	8.0	8.3	8.8	10.3	10.8
BAR	75/63		6.8	6.9	8.1	8.8	8.8	8.5	8.9	9.3	10.9	11.4
BAR	80/67		7.2	7.3	8.7	9.7	9.5	9.1	9.3	9.8	11.4	12.1
BAR	90/73		7.9	8.0	9.8	10.7	10.5	9.7	10.2	10.8	12.6	13.3

°F (°C)	ODT		0(-17)	5(-15)	15 (9.44)	45 (7.22)	75 (23.89)	85 (29.44)	95 (35)	105 (40.56)	115 (46.11)	120 (48.89)
	IDT											
PSI	70/59		95	96	108	118	121	115	119	128	150	157
PSI	75/63		99	101	117	128	126	122	129	135	158	165
PSI	80/67		105	106	125	141	138	132	135	143	165	176
PSI	90/73		114	115	142	155	152	141	148	157	184	193

°F (°C)	ODT		0(-17)	5(-15)	15 (9.44)	45 (7.22)	75 (23.89)	85 (29.44)	95 (35)	105 (40.56)	115 (46.11)	120 (48.89)
	IDT											
MPA	70/59		0.65	0.66	0.74	0.82	0.84	0.80	0.83	0.88	1.03	1.08
MPA	75/63		0.68	0.69	0.81	0.88	0.88	0.85	0.89	0.93	1.09	1.14
MPA	80/67		0.72	0.73	0.87	0.97	0.95	0.91	0.93	0.98	1.14	1.21
MPA	90/73		0.79	0.80	0.98	1.07	1.05	0.97	1.02	1.08	1.26	1.33

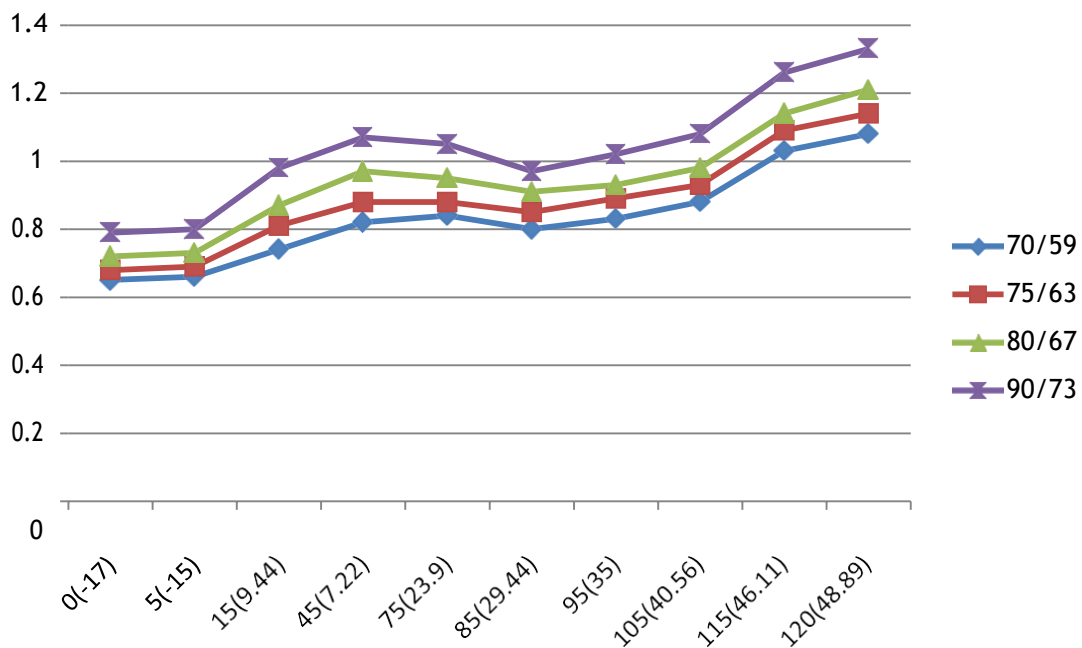

Heating chart:

°F (°C)	ODT IDT	57/53 (13.89/11.67)	47/43 (8.33/6.11)	37/33 (2.78/0.56)	27/23 (-2.78/-5)	17/13 (-8.33/ -10.56)	0/-2(-17/-19)	-17/-18 (-27/-28)
BAR	55	30.9	29.1	25.8	23.3	21.2	18.9	16.8
BAR	65	33.2	30.6	27.1	25.9	23.8	20.9	19.4
BAR	75	34.5	32.1	28.4	26.8	25.4	21.9	20.4

°F (°C)	ODT IDT	57/53 (13.89/11.67)	47/43 (8.33/6.11)	37/33 (2.78/0.56)	27/23 (-2.78/-5)	17/13 (-8.33/ -10.56)	0/-2(-17/-19)	-17/-18 (-27/-28)
PSI	55	448	421	374	337	308	273	244
PSI	65	480	444	394	375	346	303	282
PSI	75	499	466	411	389	369	318	296

°F (°C)	ODT IDT	57/53 (13.89/11.67)	47/43 (8.33/6.11)	37/33 (2.78/0.56)	27/23 (-2.78/-5)	17/13 (-8.33/ -10.56)	0/-2(-17/-19)	-17/-18 (-27/-28)
MPA	55	3.09	2.91	2.58	2.33	2.12	1.89	1.68
MPA	65	3.32	3.06	2.71	2.59	2.38	2.09	1.94
MPA	75	3.45	3.21	2.84	2.68	2.54	2.19	2.04

